

# TSUBAKI TIMING BELTS & PULLEYS PX/ULTRA PX



# All for the custome

Since TSUBAKI's "Timing Belt Drive" was introduced to the market in 1973, the timing belts and pulleys have ceaselessly been improved and new models developed to meet diversified needs of our valued customers. As an integrated manufacturer of power transmission products, TSUBAKI makes full use of its know-how and high engineering capability to continue to offer products that meet customers' satisfaction.

We believe you will find in this brochure "Timing Belts and Pulleys" that meet your needs.



# r's delight





## Contents

Overview .....	5 ~ 10
Belt Types and Dimensions .....	11 ~ 28
Transmission Capacity Tables .....	29 ~ 37
Selection and Design .....	39 ~ 50
Pulleys .....	51 ~ 65
Instruction Manual .....	66 ~ 67
Pitch and Outside Diameter .....	68 ~ 69







# Instruction Manual

## For safe use of timing belts and pulleys



In order to ensure correct handling of the products, please make sure to read the belt catalog and instructions thoroughly upon use paying close attention to the items below, which have been classified according to the degree of influence on safety.

Terms	Definition
 <b>Danger</b>	When it is assumed that death or serious personal injury is imminent as a result of incorrect handling.
 <b>Warning</b>	When it is assumed that death or serious personal injury is possible as a result of incorrect handling.
 <b>Caution</b>	When it is assumed that there is a risk of personal injury and/or material damage as a result of incorrect handling.



### ■ Applications and Objectives of Use

-  **Danger** When it is foreseen that idling and equipment stoppage caused by damage or cutting of the belt will lead to an accident resulting in death or serious personal injury, make sure to install a safety device.
-  **Danger** Do not use the belt as a harness or tow rope.
-  **Warning** When it is foreseen that static electricity generated by operation of the belt may lead to the mistaken use of a fire extinguisher, please install a static electricity prevention device in the equipment.
-  **Caution** Do not use the belt as an insulator. Since insulating properties vary depending on the type of belt, please consult Tsubaki.
-  **Caution** When the belt comes into direct contact with food, make sure to use a belt which complies with the Food Sanitation Law.
-  **Caution** Do not carry out additional processing on the belt. Quality and performance of the belt is likely to deteriorate as a result.









### ■ Function and Performance

-  **Caution** Do not use the belt in any way other than indicated in each belt catalog, design data, etc. or outside the tolerance levels. Premature breakage of the belt may occur.
-  **Caution** Adhesion of water, oil, chemicals, paint, dust, etc. to the pulley or belt will result in deterioration of transmission power and possibly cause premature breakage.
-  **Caution** Noise may become large during high-speed operation of the belt. In this case, please install a sound insulation cover.

### ■ Storage and Transportation

-  **Caution** When transporting or handling heavy belts and pulleys, make sure to use transportation equipment/apparatuses, etc. suitable for the weight involved.
-  **Caution** Do not forcefully bend or place heavy items on the belt during transportation or storage, as this will result in creasing/damage and cause premature breakage of the belt.
-  **Caution** Keep the belt stored at a temperature range of -10°C to +40°C in a low humidity place. Besides, do not expose the belt to direct sunlight during storage.

### ■ Installation and Mobility

-  **Danger** Make sure to install a safety cover over all rotating parts including the belt and pulley. There is a possibility of hair, gloves, clothes, etc. getting caught in the belt and pulley. Moreover, breakage of the belt or pulley may cause an injury from flying fragments.
-  **Danger** Abide by the following during maintenance, inspection or replacement of the belt and pulley.
  - (1) Make sure to disconnect the power and wait for the belt and pulley to stop completely before starting.
  - (2) Where there is a possibility of the machine starting from removal of the belt, secure the machine in advance before starting work.
  - (3) Ensure that the power can not be switched on accidentally.
-  **Caution** When replacing the belt or pulley, ensure that the same type is used. Replacement with a different type may lead to premature breakage.
-  **Caution** Deviation in the pulley alignment will cause premature breakage or flange omission. Please carry out adjustments as required.
-  **Caution** Loosen the belt tension when replacing it. Do not force the belt over the flange of the pulley by using a screwdriver or similar implement, as this will cause premature breakage of the belt.
-  **Caution** When installing the belt, make sure to use proper tension as indicated in the catalog and design data. Improper tension may result in premature breakage of the belt and shaft.
-  **Caution** Carry out the following when additional processing on the pulley is required before use :
  - (1) Remove burrs and sharp corners ;
  - (2) Check precision of dimensions after processing ;
  - (3) Check strength of pulley after processing.
-  **Caution** When attaching the flange to the pulley, make sure no foreign particles exist between the pulley and flange, and secure them to prevent rattling in the flange by calking. Unsuitable fitting will cause the flange to come off.

### ■ Inspection

-  **Caution** Carry out regular inspections of the belt and pulley, and replace them when you notice anything out of the ordinary.

### ■ Handling of Used Items

-  **Caution** Do not burn the belt. Harmful gasses may be generated.

# Warranty

## 1. Warranty period without charge

Our company warrants the product free of charge for 18 months after shipment from our factory and 12 months after the product is used first (reckoned from the date of assembly of the product in customer's equipment), whichever shorter. However, charges may be incurred, depending on conditions.

## 2. Warranty range

If any problems are found in the product within the warranty period and our company confirms that the customer has carried out proper installation, operation, maintenance, and control of the product in accordance with the catalog, manuals, and so forth, our company will supply our product or parts or repair the defective product immediately free of charge. The warranty applies to the supplied product only. The warranty does not apply to the following expenses. ("Manuals and so forth" include documents supplied to the customer.)

- (1) Costs of detaching and attaching our product from/to customer's equipment for replacing or repairing our product and costs of related work
- (2) Costs of transporting customer's equipment to the repair shop
- (3) Customer's profit loss due to problems or repair service and other consequential losses

## 3. Onerous warranty

Our company will undertake investigation, repair, or manufacturing for counter value even in the warranty period without charge, if problems are found in our products for the following causes:

- (1) If the customer fails to carry out proper layout, installation (including connection), lubrication, maintenance, or control according to the catalog, manuals, etc. ("Manuals, etc." include documents especially supplied to the customer.)
- (2) If the customer uses the product (including the use conditions, environment and allowable values) in contravention of the catalog, manuals, etc. ("Manuals, etc." include documents especially supplied to the customer.)
- (3) If the customer disassembles, modifies, or processes the product improperly
- (4) If the customer uses our product with damaged or worn products (for example, using the chain with worn sprocket, drum, rail, etc.)
- (5) If the service life selected by our company in the use conditions does not meet the warranted service life
- (6) If the customer uses the product under different conditions from the agreed conditions
- (7) If consumable parts, such as bearings, oil seals, or oil, assembled in our product are consumed, worn, or deteriorated
- (8) If our product suffers from secondary problems caused by customer's equipment
- (9) If our product suffers from problems caused by a disaster or irresistible forces
- (10) If our product suffers from problems caused by illegal actions of third parties
- (11) If our product suffers from problems not chargeable to our company

# Over view

## Features

### Precision drive

As a mechanism of engaged-drive, timing belts realize precision drive with only little belt elongation.

### Low noise drive

Compared to other power transmission elements such as gears, timing belts offer low-noise and smooth drive.

### Lube-free

Timing belts are lube-free allowing a clean drive without spillage or contamination.

### High-efficiency rating

Timing belts can transmit power efficiently with minimal energy loss.

### High-speed drive

Timing belts can be operated at high-speed compared to other power transmission parts such as gears.

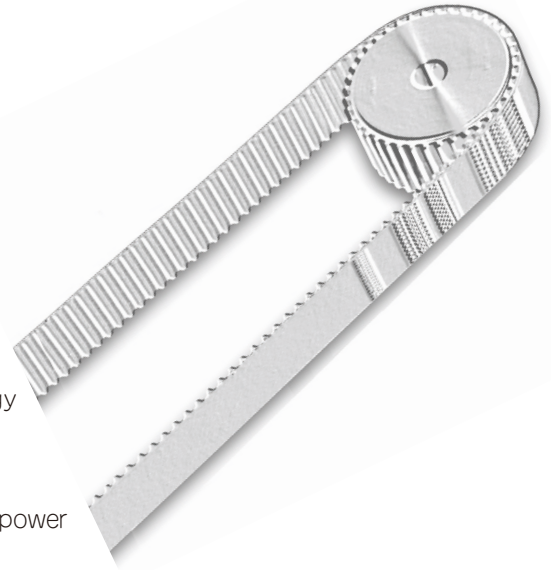

## Structure & Materials

- **Backing** : Durable and wear-resistant rubber  
(High Intensity Synthetic rubber)
- **Cord** : Fiberglass with very minimal growth
- **Tooth rubber** : Same material as the backing to realize high-power drive
- **Fabric** : Nylon with superior wear-resistance

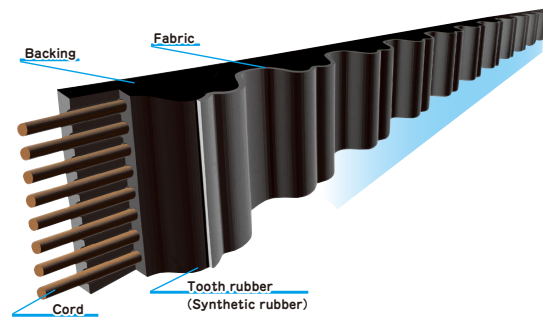

## Line-Up

Series	Pitch Size		Endless (Standard)	Open-Ended	Water Proof
	Type	Pitch mm			
PX BELT	P2M	2.00	○	○	
	P3M	3.00	SHINAYAKA530	○	
	P5M	5.00	○	○	○
	P8M	8.00	○	○	○
	P14M	14.00	○		
ULTRA PX BELT HC TYPE	UP3M-HC	3.00	○	○	
	UP5M-HC	5.00	○	○	
	UP8M-HC	8.00	○	○	
	UP14M-HC	14.00	○		
ULTRA PX BELT OIL-PROOF TYPE	UP5M-HA	5.00	○		
	UP8M-HA	8.00	○		
ULTRA PX BELT HY TYPE	UP3M-HY	3.00	○		
	UP5M-HY	5.00	○		
	UP8M-HY	8.00	○		
	UP14M-HY	14.00	○		

# PRODUCT Line-Up [ 1 ]

## PX BELT

Compared to the trapezoidal belt, the performance of TSUBAKI PX belt is improved sharply through the adoption of a unique tooth contour. Moreover, there is an abundance of sizes available in the line-up to suit a variety of applications.



### Features

- **Ideal tooth engagement**  
The unique contour of the teeth enables high torque drive. Transmission capacity is about 1.6 times that of the trapezoidal belt.
- **High jumping torque**  
Large belt teeth provide high jumping torque capabilities.
- **Low noise**  
Low-noise drive is made possible by the adoption of a unique dimple on the tooth ends.
- **High precision**  
Since the mechanism of “teeth-in-mesh” is a “just touch” system, both the top and bottom of the belt contact the pulley enabling high precision drive.

**P2M** (Belt pitch **2 mm**)      **P8M** (Belt pitch **8 mm**)  
**P3M** (Belt pitch **3 mm**)      **P14M** (Belt pitch **14 mm**)  
**P5M** (Belt pitch **5 mm**)

### ■ Dimple

Before engagement ← → After engagement

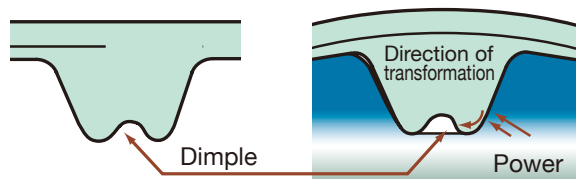

### ■ Just Touch System

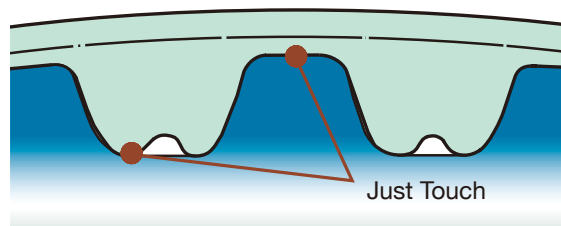

## ULTRA PX BELT HC TYPE    PATENTED : JP,US,DE,GB,FR,IT

“HC” type is the high performance version of ULTRA PX belt. HC type offers the following features in addition to those of ULTRA PX belt.

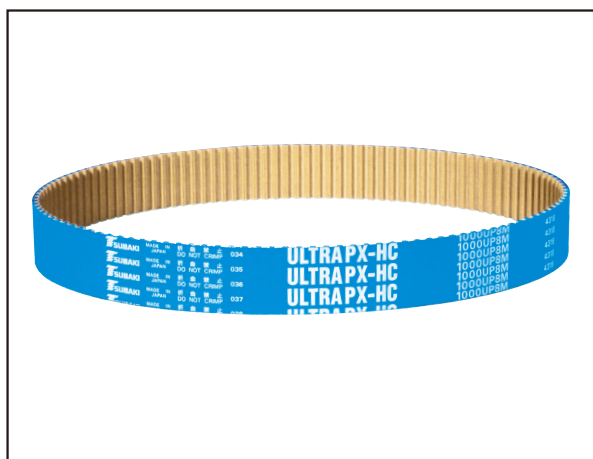

### Features

- **High Precision**  
Almost free from reduction of the installation tension. Capable of precision transmission at low set tension.
- **High Intensity**  
Enables transmission of higher loads and a more compact design.
- **Clean**  
Improved abrasion resistance of the tooth cloth suppresses scattering of wear powder.
- **Color**  
Color of the tooth cloth is changed. Rubber exposure due to wear of the tooth cloth can be found easily.

**UP3M-HC** (Belt pitch **3 mm**)      **UP8M-HC** (Belt pitch **8 mm**)  
**UP5M-HC** (Belt pitch **5 mm**)      **UP14M-HC** (Belt pitch **14 mm**)

# Features of Ultra PX Belt HC Type

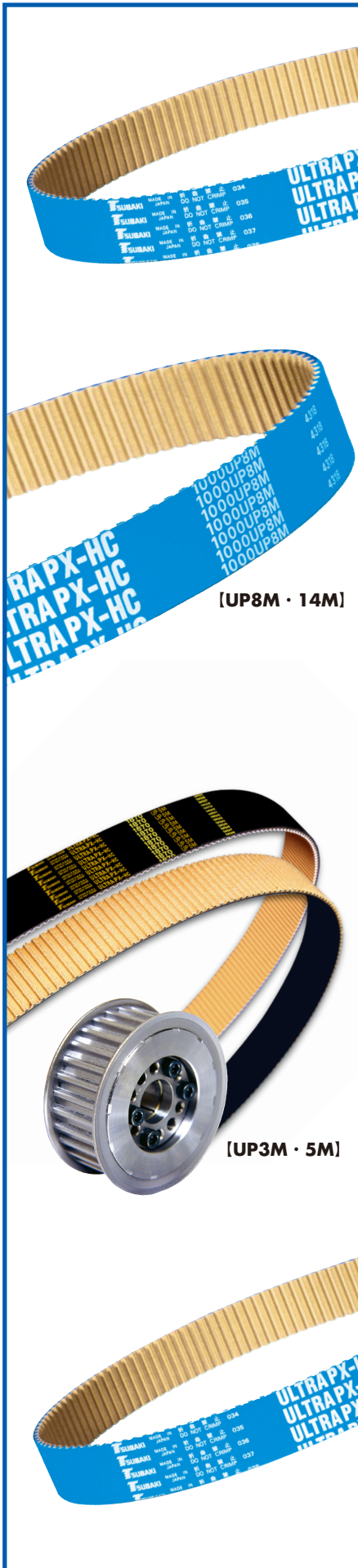

## 1 High precision

Halved operation elongation improves the transmission accuracy, which improves the precision of the equipment and eliminates the need for a belt tension re-adjustment.

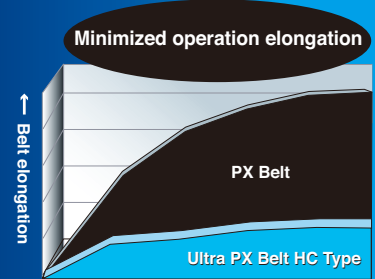

Operation time & belt elongation

## 2 High strength

The transmission capability is twice or more as high as the conventional PX belts. The belt width or the number of teeth of pulley can be reduced, allowing for a space-saving design.

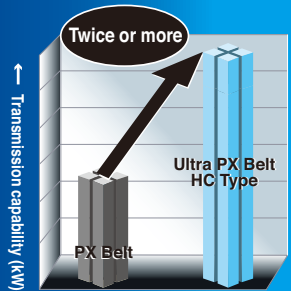

Comparison of transmission capability

## 3 Clean

Abrasion-resistant tooth cloth reduces scattering of wear powder and enables clean transmission.



## 4 Color

UP8M  
UP14M

**Blue** tooth rubber allows the wear condition to be checked at a glance.

NOTE: This shows signs of replacing the belt.  
NOTE: The wear condition can be checked more clearly if the tooth surface of the belt is wiped with ethanol.

NOTE: The UP3M and 5M use black rubber.

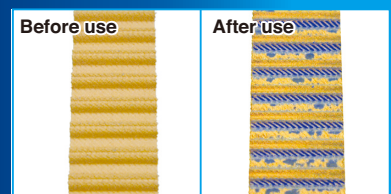



# PRODUCT Line-Up [ 2 ]

## OPEN-ENDED BELT



### Features

- Suitable for reciprocating movement, such as a cart drive or the opening/closing of a door.
- Long-span drive is available.
- ULTRA PX belt has also been added to the line-up, so high-torque drive is now possible.

**P2M** (Belt pitch **2 mm**)  
**P3M, UP3M-HC** (Belt pitch **3 mm**)  
**P5M, UP5M-HC** (Belt pitch **5 mm**)  
**P8M, UP8M-HC** (Belt pitch **8 mm**)

## SHINAYAKA 530 BELT



### Features

- SHINAYAKA 530 belt is suitable for clean drives, as there is very minimal wear dust generated from the belt.
- SHINAYAKA 530 belt is flexible enough that initial tension can be set at a low level and axial load can be reduced.
- P2M, and P3M specifications are all standard.

**P2M-530** (Belt pitch **2 mm**)  
**P3M-530** (Belt pitch **3 mm**)

# PRODUCT Line-Up [ 3 ]

## ULTRA PX BELT OIL-PROOF TYPE PATENTED : JP,US,DE,GB,FR,IT

Oil-proof type belt developed based on the high-performance belt ultra PX belt HC type

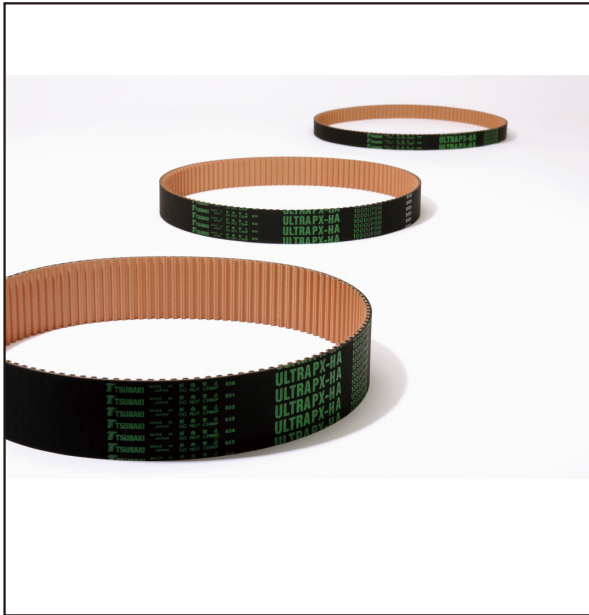

### Features

#### Oil-proof

Oil-proof rubber is used for the belt. Even in conditions subject to oil splashes, the physical properties of the belt are hardly reduced. The belt can be used in conditions subject to oil splashes.

#### High strength and high precision

This belt features equivalent transmission capability to the ultra PX belt HC type. Besides, it features very little operation elongation, allowing high-precision transmission.

\*Resistance for all oil types and use conditions is not warranted.

It is recommended that the product should be used with the equipment in use.

**UP5M-HA** (Belt pitch **5 mm**)

**UP8M-HA** (Belt pitch **8 mm**)

These are made to order, though we received an order of a single belt.

## ULTRA PX BELT HY TYPE PATENTED : JP,US,DE,GB,FR,IT

A hybrid glass and carbon core increases the strength and rigidity remarkably.



### Features

#### Ultra-high strength

The hybrid core made of especially-processed rigid carbon and glass fibers features high transmission capability. This belt has 1.3 to 2.0 times as high the transmission capability as the ultra PX belt HC type. It enables size and weight reduction of the equipment.

#### Ultra-high rigidity

A hybrid core reduces load elongation. This product enables high-speed large load transmission. It enables high-speed operation of the equipment by remarkably shortening the attenuation time and reducing the maximum amplitude.

**UP3M-HY** (Belt pitch **3 mm**) **UP8M-HY** (Belt pitch **8 mm**)

**UP5M-HY** (Belt pitch **5 mm**) **UP14M-HY** (Belt pitch **14 mm**)

These are made to order. Place orders in units of lots.

\* The standard pulleys can be used for the UP3M, 5M and 8M-HY.

The UP14M-HY requires an exclusive pulley (custom-made product).

\* Refer to the separate catalog for details.

# PRODUCT Line-Up [ 4 ]

## PX BELT WATER PROOF TYPE

Belt most suitable for use in wet environment.



### Features

#### ■ Most suitable for use in wet environment

This belt can be used in wet environment where conventional timing belts cannot be used. It can be used in machines that are washed by water. When this belt is used, the waterproof cover can be simplified.

#### ■ Clean, low noise and high precision

This is a timing belt and thus produces less noise than other drive elements and provides cleaner drive. No lubrication is required.

#### ■ PX standard pulleys can be used

Since the PX tooth profile is employed, this can be used with PX standard pulleys.

**P5M-W** (Belt pitch **5 mm**)

**P8M-W** (Belt pitch **8 mm**)

## P2M (P : 2 mm)

### ■ Belt Tooth Profile and Dimensions

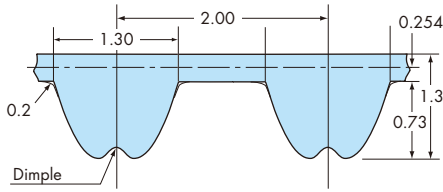

### ■ Model Identification

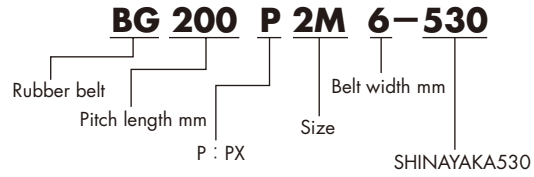

### ■ Materials

Rubber : Chloroprene rubber  
 Fabric : Nylon fabric (Low dust specification)  
 Cord : Fiberglass

### ■ Specifications and Characteristic

Pulley : PX Pulley P2M      Oil proof, Water proof : No ( Unusable )  
 Temperature Range : -15°C ~ +80°C      RoHS Directive : Compliance  
 Conductive property : No

### ■ Belt Width / Width Factor / Unit Mass / Installation Tension

Belt width mm	Belt width factor	Weight kg/m	Installation Tension N {kgf}	
			Recommended	Max. Value
4	1.00	0.006	5.9 {0.6}	7.8 {0.8}
6	1.59	0.008	9.8 {1.0}	13 {1.3}
10	2.84	0.014	17 {1.7}	23 {2.3}

 Transmission Capacity Tables P29

 Selection and Design P39

### ■ Belt Length

Belt length	No. of teeth	Belt length	No. of teeth	Belt length	No. of teeth	Belt length	No. of teeth	Belt length	No. of teeth
<b>BG80P2M</b>	40	<b>BG172P2M</b>	86	<b>BG274P2M</b>	137	<b>BG416P2M</b>	208	<b>BG754P2M</b>	377
<b>BG84P2M</b>	42	<b>BG176P2M</b>	88	<b>BG280P2M</b>	140	<b>BG420P2M</b>	210	<b>BG764P2M</b>	382
<b>BG88P2M</b>	44	<b>BG180P2M</b>	90	<b>BG284P2M</b>	142	<b>BG424P2M</b>	212	<b>BG774P2M</b>	387
<b>BG98P2M</b>	49	<b>BG186P2M</b>	93	<b>BG290P2M</b>	145	<b>BG426P2M</b>	213	<b>BG788P2M</b>	394
<b>BG100P2M</b>	50	<b>BG190P2M</b>	95	BG296P2M	148	<b>BG434P2M</b>	217	<b>BG800P2M</b>	400
<b>BG112P2M</b>	56	<b>BG196P2M</b>	98	BG298P2M	149	<b>BG440P2M</b>	220	<b>BG808P2M</b>	404
<b>BG116P2M</b>	58	<b>BG200P2M</b>	100	<b>BG300P2M</b>	150	<b>BG448P2M</b>	224	<b>BG824P2M</b>	412
<b>BG118P2M</b>	59	<b>BG204P2M</b>	102	<b>BG302P2M</b>	151	<b>BG464P2M</b>	232	<b>BG846P2M</b>	423
<b>BG124P2M</b>	62	<b>BG208P2M</b>	104	<b>BG310P2M</b>	155	<b>BG488P2M</b>	244	<b>BG866P2M</b>	433
<b>BG126P2M</b>	63	<b>BG212P2M</b>	106	<b>BG318P2M</b>	159	<b>BG490P2M</b>	245	<b>BG898P2M</b>	449
<b>BG132P2M</b>	66	<b>BG214P2M</b>	107	<b>BG320P2M</b>	160	<b>BG500P2M</b>	250	<b>BG900P2M</b>	450
<b>BG134P2M</b>	67	<b>BG216P2M</b>	108	<b>BG324P2M</b>	162	<b>BG516P2M</b>	258	<b>BG940P2M</b>	470
<b>BG136P2M</b>	68	<b>BG220P2M</b>	110	<b>BG328P2M</b>	164	<b>BG520P2M</b>	260	<b>BG956P2M</b>	478
<b>BG140P2M</b>	70	<b>BG224P2M</b>	112	<b>BG330P2M</b>	165	<b>BG530P2M</b>	265	<b>BG992P2M</b>	496
<b>BG142P2M</b>	71	<b>BG230P2M</b>	115	<b>BG334P2M</b>	167	<b>BG560P2M</b>	280	<b>BG1040P2M</b>	520
<b>BG144P2M</b>	72	<b>BG234P2M</b>	117	<b>BG340P2M</b>	170	<b>BG576P2M</b>	288	<b>BG1110P2M</b>	555
<b>BG146P2M</b>	73	<b>BG236P2M</b>	118	<b>BG348P2M</b>	174	<b>BG590P2M</b>	295	<b>BG1150P2M</b>	575
<b>BG152P2M</b>	76	<b>BG240P2M</b>	120	<b>BG354P2M</b>	177	<b>BG600P2M</b>	300	<b>BG1158P2M</b>	579
<b>BG154P2M</b>	77	<b>BG244P2M</b>	122	<b>BG360P2M</b>	180	<b>BG630P2M</b>	315	<b>BG1182P2M</b>	591
<b>BG160P2M</b>	80	<b>BG246P2M</b>	123	<b>BG370P2M</b>	185	<b>BG638P2M</b>	319	<b>BG1192P2M</b>	596
<b>BG162P2M</b>	81	<b>BG250P2M</b>	125	<b>BG378P2M</b>	189	<b>BG656P2M</b>	328	<b>BG1242P2M</b>	621
BG164P2M	82	<b>BG258P2M</b>	129	<b>BG380P2M</b>	190	<b>BG676P2M</b>	338	<b>BG1410P2M</b>	705
<b>BG166P2M</b>	83	<b>BG262P2M</b>	131	<b>BG390P2M</b>	195	<b>BG680P2M</b>	340	<b>BG1526P2M</b>	763
<b>BG168P2M</b>	84	<b>BG266P2M</b>	133	<b>BG400P2M</b>	200	<b>BG704P2M</b>	352	<b>BG1700P2M</b>	850
<b>BG170P2M</b>	85	<b>BG270P2M</b>	135	<b>BG408P2M</b>	204	<b>BG710P2M</b>	355	<b>BG1820P2M</b>	910

· Bold Font : Stock item Fine Font : Made to order, but in short lead time.

### ■ Pulley Dimensions (Reference)

No. of teeth	Pitch circle dia	Flange OD	No. of teeth	Pitch circle dia	Flange OD	No. of teeth	Pitch circle dia	Flange OD	No. of teeth	Pitch circle dia	Flange OD
<b>14</b>	8.91	12	<b>22</b>	14.01	17	<b>30</b>	19.10	26	<b>42</b>	26.74	32
<b>15</b>	9.55	13	<b>24</b>	15.28	17	<b>32</b>	20.37	28	<b>44</b>	28.01	34
<b>16</b>	10.19	13	<b>25</b>	15.92	21	<b>34</b>	21.65	28	<b>48</b>	30.56	36
<b>18</b>	11.46	15	<b>26</b>	16.55	21	<b>36</b>	22.92	29	<b>50</b>	31.83	39
<b>20</b>	12.73	17	<b>28</b>	17.83	25	<b>40</b>	25.46	32	<b>60</b>	38.20	45

 Pulley Specifications P51

## P3M (P : 3 mm)

### ■ Belt Tooth Profile and Dimensions

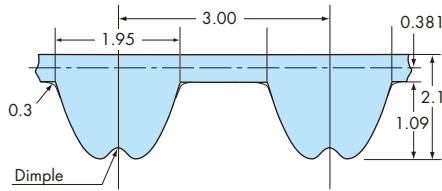

### ■ Model Identification

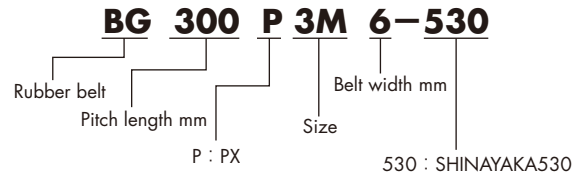

### ■ Materials

Rubber : Chloroprene rubber  
 Fabric : Nylon fabric (Low dust specification)  
 Cord : Fiberglass

### ■ Specifications and Characteristic

Pulley : PX Pulley P3M      Oil proof, Water proof : No ( Unusable )  
 Temperature Range : -15°C~+80°C      RoHS Directive : Compliance  
 Conductive property : No

### ■ Belt Width / Width Factor / Unit Mass / Installation Tension

Belt width mm	Belt width factor	Weight kg/m	Installation Tension N {kgf}	
			Recommended	Max. Value
6	1.00	0.013	20 {2.0}	26 {2.7}
10	1.78	0.022	34 {3.5}	46 {4.7}
15	2.84	0.034	55 {5.6}	74 {7.5}

 Transmission Capacity Tables P30

 Selection and Design P39

### ■ Belt Length

Belt length	No. of teeth	Belt length	No. of teeth	Belt length	No. of teeth	Belt length	No. of teeth	Belt length	No. of teeth	Belt length	No. of teeth
<b>BG120P3M</b>	40	<b>BG225P3M</b>	75	BG315P3M	105	<b>BG447P3M</b>	149	<b>BG693P3M</b>	231	<b>BG1041P3M</b>	347
<b>BG123P3M</b>	41	BG228P3M	76	<b>BG318P3M</b>	106	<b>BG450P3M</b>	150	<b>BG699P3M</b>	233	<b>BG1050P3M</b>	350
BG132P3M	44	<b>BG231P3M</b>	77	BG327P3M	109	<b>BG453P3M</b>	151	<b>BG702P3M</b>	234	<b>BG1059P3M</b>	353
<b>BG138P3M</b>	46	<b>BG234P3M</b>	78	<b>BG330P3M</b>	110	<b>BG459P3M</b>	153	<b>BG705P3M</b>	235	<b>BG1080P3M</b>	360
<b>BG141P3M</b>	47	<b>BG237P3M</b>	79	<b>BG339P3M</b>	113	BG471P3M	157	<b>BG720P3M</b>	240	<b>BG1110P3M</b>	370
<b>BG144P3M</b>	48	<b>BG240P3M</b>	80	BG342P3M	114	<b>BG477P3M</b>	159	<b>BG738P3M</b>	246	<b>BG1170P3M</b>	390
<b>BG147P3M</b>	49	<b>BG243P3M</b>	81	<b>BG345P3M</b>	115	<b>BG483P3M</b>	161	<b>BG753P3M</b>	251	<b>BG1191P3M</b>	397
<b>BG150P3M</b>	50	<b>BG246P3M</b>	82	BG351P3M	117	<b>BG486P3M</b>	162	<b>BG756P3M</b>	252	<b>BG1281P3M</b>	427
<b>BG153P3M</b>	51	<b>BG252P3M</b>	84	<b>BG354P3M</b>	118	<b>BG489P3M</b>	163	<b>BG789P3M</b>	263	<b>BG1305P3M</b>	435
<b>BG159P3M</b>	53	<b>BG255P3M</b>	85	<b>BG360P3M</b>	120	<b>BG501P3M</b>	167	<b>BG804P3M</b>	268	<b>BG1338P3M</b>	446
<b>BG162P3M</b>	54	<b>BG264P3M</b>	88	<b>BG363P3M</b>	121	<b>BG504P3M</b>	168	BG822P3M	274	<b>BG1344P3M</b>	448
<b>BG171P3M</b>	57	BG267P3M	89	<b>BG369P3M</b>	123	<b>BG507P3M</b>	169	<b>BG852P3M</b>	284	<b>BG1380P3M</b>	460
<b>BG174P3M</b>	58	<b>BG270P3M</b>	90	<b>BG372P3M</b>	124	<b>BG510P3M</b>	170	<b>BG861P3M</b>	287	<b>BG1443P3M</b>	481
<b>BG177P3M</b>	59	<b>BG273P3M</b>	91	<b>BG378P3M</b>	126	<b>BG525P3M</b>	175	BG870P3M	290	<b>BG1638P3M</b>	546
<b>BG183P3M</b>	61	<b>BG276P3M</b>	92	<b>BG384P3M</b>	128	<b>BG537P3M</b>	179	<b>BG879P3M</b>	293	<b>BG1689P3M</b>	563
<b>BG186P3M</b>	62	<b>BG279P3M</b>	93	<b>BG387P3M</b>	129	<b>BG552P3M</b>	184	BG885P3M	295	<b>BG1749P3M</b>	583
<b>BG192P3M</b>	64	<b>BG285P3M</b>	95	<b>BG393P3M</b>	131	<b>BG561P3M</b>	187	<b>BG891P3M</b>	297	<b>BG1893P3M</b>	631
<b>BG195P3M</b>	65	<b>BG288P3M</b>	96	<b>BG399P3M</b>	133	<b>BG588P3M</b>	196	<b>BG918P3M</b>	306	<b>BG1947P3M</b>	649
<b>BG198P3M</b>	66	<b>BG291P3M</b>	97	<b>BG402P3M</b>	134	<b>BG600P3M</b>	200	<b>BG933P3M</b>	311		
<b>BG201P3M</b>	67	<b>BG294P3M</b>	98	<b>BG405P3M</b>	135	BG618P3M	206	<b>BG948P3M</b>	316		
<b>BG207P3M</b>	69	<b>BG300P3M</b>	100	<b>BG411P3M</b>	137	<b>BG633P3M</b>	211	<b>BG957P3M</b>	319		
<b>BG210P3M</b>	70	<b>BG303P3M</b>	101	<b>BG420P3M</b>	140	<b>BG660P3M</b>	220	<b>BG972P3M</b>	324		
<b>BG213P3M</b>	71	<b>BG306P3M</b>	102	<b>BG423P3M</b>	141	<b>BG675P3M</b>	225	BG981P3M	327		
<b>BG219P3M</b>	73	<b>BG309P3M</b>	103	<b>BG432P3M</b>	144	<b>BG681P3M</b>	227	<b>BG1005P3M</b>	335		
<b>BG222P3M</b>	74	<b>BG312P3M</b>	104	<b>BG438P3M</b>	146	<b>BG687P3M</b>	229	<b>BG1023P3M</b>	341		

· Bold Font : Stock item Fine Font : Made to order, but in short lead time.

### ■ Pulley Dimensions (Reference)

No. of teeth	Pitch circle dia	Flange OD	No. of teeth	Pitch circle dia	Flange OD	No. of teeth	Pitch circle dia	Flange OD	No. of teeth	Pitch circle dia	Flange OD
<b>10</b>	9.55	12	<b>18</b>	17.19	21	<b>26</b>	24.83	31	<b>40</b>	38.20	45
<b>12</b>	11.46	15	<b>20</b>	19.10	25	<b>28</b>	26.74	32	<b>48</b>	45.84	52
<b>14</b>	13.37	17	<b>22</b>	21.01	28	<b>30</b>	28.65	34	<b>50</b>	47.75	55
<b>15</b>	14.32	17	<b>24</b>	22.92	29	<b>32</b>	30.56	36	<b>60</b>	57.30	65
<b>16</b>	15.28	17	<b>25</b>	23.87	31	<b>36</b>	34.38	43			

 Pulley Specifications P52

## P5M (P : 5 mm)

### ■ Belt Tooth Profile and Dimensions

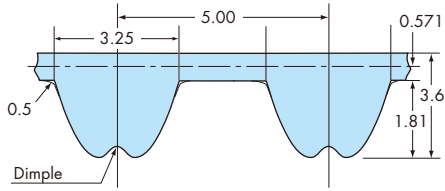

### ■ Model Identification

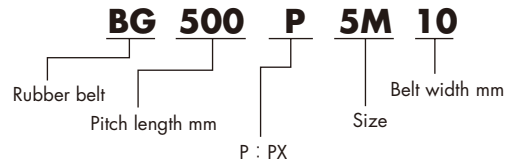

### ■ Materials

Rubber : Chloroprene rubber  
 Fabric : Nylon fabric  
 Cord : Fiberglass

### ■ Specifications and Characteristic

Pulley : PX Pulley P5M      Oil proof, Water proof : No ( Unusable )  
 Temperature Range : -15°C ~ +80°C      RoHS Directive : Compliance  
 Conductive property : No

### ■ Belt Width / Width Factor / Unit Mass / Installation Tension

Belt width mm	Belt width factor	Weight kg/m	Installation Tension N {kgf}	
			Recommended	Max. Value
10	1.00	0.041	108 {11.0}	147 {15.0}
15	1.59	0.062	167 {17.0}	225 {23.0}
25	2.84	0.103	304 {31.0}	412 {42.0}

 Transmission Capacity Tables P31

 Selection and Design P39

### ■ Belt Length

Belt length	No. of teeth	Belt length	No. of teeth	Belt length	No. of teeth	Belt length	No. of teeth	Belt length	No. of teeth
<b>BG175P5M</b>	35	<b>BG490P5M</b>	98	<b>BG695P5M</b>	139	<b>BG1000P5M</b>	200	BG1585P5M	317
<b>BG215P5M</b>	43	<b>BG500P5M</b>	100	<b>BG700P5M</b>	140	<b>BG1025P5M</b>	205	<b>BG1595P5M</b>	319
<b>BG225P5M</b>	45	<b>BG515P5M</b>	103	<b>BG710P5M</b>	142	<b>BG1050P5M</b>	210	<b>BG1615P5M</b>	323
<b>BG255P5M</b>	51	<b>BG520P5M</b>	104	<b>BG725P5M</b>	145	<b>BG1060P5M</b>	212	<b>BG1675P5M</b>	335
<b>BG260P5M</b>	52	<b>BG525P5M</b>	105	<b>BG730P5M</b>	146	BG1080P5M	216	<b>BG1700P5M</b>	340
<b>BG275P5M</b>	55	<b>BG530P5M</b>	106	<b>BG740P5M</b>	148	<b>BG1090P5M</b>	218	<b>BG1800P5M</b>	360
<b>BG295P5M</b>	59	<b>BG545P5M</b>	109	<b>BG750P5M</b>	150	<b>BG1125P5M</b>	225	<b>BG1870P5M</b>	374
<b>BG300P5M</b>	60	<b>BG550P5M</b>	110	<b>BG765P5M</b>	153	BG1145P5M	229	<b>BG1910P5M</b>	382
<b>BG310P5M</b>	62	<b>BG555P5M</b>	111	<b>BG770P5M</b>	154	<b>BG1150P5M</b>	230	<b>BG1960P5M</b>	392
<b>BG320P5M</b>	64	<b>BG560P5M</b>	112	<b>BG775P5M</b>	155	<b>BG1160P5M</b>	232	<b>BG2000P5M</b>	400
<b>BG325P5M</b>	65	<b>BG565P5M</b>	113	<b>BG780P5M</b>	156	<b>BG1180P5M</b>	236	<b>BG2080P5M</b>	416
<b>BG340P5M</b>	68	<b>BG570P5M</b>	114	<b>BG800P5M</b>	160	<b>BG1195P5M</b>	239	<b>BG2160P5M</b>	432
BG345P5M	69	<b>BG575P5M</b>	115	<b>BG810P5M</b>	162	<b>BG1220P5M</b>	244	<b>BG2200P5M</b>	440
<b>BG350P5M</b>	70	<b>BG595P5M</b>	119	<b>BG830P5M</b>	166	<b>BG1225P5M</b>	245	BG2455P5M	491
<b>BG370P5M</b>	74	<b>BG600P5M</b>	120	<b>BG835P5M</b>	167	<b>BG1250P5M</b>	250	<b>BG2645P5M</b>	529
<b>BG375P5M</b>	75	<b>BG605P5M</b>	121	<b>BG850P5M</b>	170	<b>BG1260P5M</b>	252	BG2725P5M	545
BG390P5M	78	<b>BG625P5M</b>	125	<b>BG865P5M</b>	173	<b>BG1270P5M</b>	254	BG2795P5M	599
<b>BG400P5M</b>	80	<b>BG635P5M</b>	127	<b>BG880P5M</b>	176	<b>BG1295P5M</b>	259	<b>BG3050P5M</b>	610
<b>BG420P5M</b>	84	BG640P5M	128	<b>BG900P5M</b>	180	<b>BG1350P5M</b>	270	<b>BG3150P5M</b>	630
<b>BG425P5M</b>	85	<b>BG645P5M</b>	129	<b>BG905P5M</b>	181	<b>BG1390P5M</b>	278	<b>BG3930P5M</b>	786
<b>BG430P5M</b>	86	<b>BG650P5M</b>	130	<b>BG920P5M</b>	184	<b>BG1420P5M</b>	284		
<b>BG440P5M</b>	88	<b>BG670P5M</b>	134	<b>BG940P5M</b>	188	<b>BG1490P5M</b>	298		
<b>BG450P5M</b>	90	<b>BG675P5M</b>	135	<b>BG950P5M</b>	190	BG1495P5M	299		
BG470P5M	94	BG680P5M	136	<b>BG965P5M</b>	193	<b>BG1530P5M</b>	306		
<b>BG475P5M</b>	95	<b>BG690P5M</b>	138	<b>BG985P5M</b>	197	<b>BG1550P5M</b>	310		

· Bold Font : Stock item Fine Font : Made to order, but in short lead time.

### ■ Pulley Dimensions (Reference)

No. of teeth	Pitch circle dia	Flange OD	No. of teeth	Pitch circle dia	Flange OD	No. of teeth	Pitch circle dia	Flange OD	No. of teeth	Pitch circle dia	Flange OD
<b>12</b>	19.10	23	<b>22</b>	35.01	43	<b>30</b>	47.75	55	<b>48</b>	76.39	82
<b>14</b>	22.28	28	<b>24</b>	38.20	44	<b>32</b>	50.93	55	<b>50</b>	79.58	86
<b>16</b>	25.46	31	<b>25</b>	39.79	45	<b>36</b>	57.30	64	<b>60</b>	95.49	103
<b>18</b>	28.65	36	<b>26</b>	41.38	47	<b>40</b>	63.66	67	<b>72</b>	114.59	120
<b>20</b>	31.83	36	<b>28</b>	44.56	52	<b>44</b>	70.03	74			

 Pulley Specifications

P53

## P8M (P : 8 mm)

### ■ Belt Tooth Profile and Dimensions

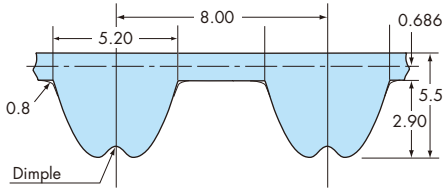

### ■ Model Identification

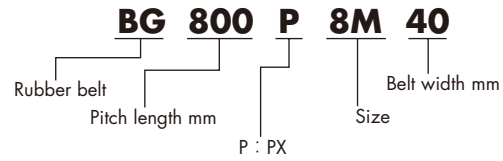

### ■ Materials



Rubber : Chloroprene rubber  
Fabric : Nylon fabric  
Cord : Fiberglass

### ■ Specifications and Characteristic

Pulley : PX Pulley P8M      Oil proof, Water proof : No ( Unusable )  
Temperature Range : -15°C ~ +80°C      RoHS Directive : Compliance  
Conductive property : No

### ■ Belt Width / Width Factor / Unit Mass / Installation Tension

Belt width mm	Belt width factor	Weight kg/m	Installation Tension N {kgf}	
			Recommended	Max. Value
15	1.00	0.084	225 {23.0}	294 {30.0}
25	1.79	0.139	382 {39.0}	510 {52.0}
40	3.06	0.223	657 {67.0}	860 {88.0}
60	4.86	0.334	1040 {106.0}	1370 {140.0}

 [Transmission Capacity Tables](#) P32  
 [Selection and Design](#) P39

### ■ Belt Length

Belt length	No. of teeth	Belt length	No. of teeth	Belt length	No. of teeth	Belt length	No. of teeth
<b>BG376P8M</b>	47	<b>BG832P8M</b>	104	<b>BG1216P8M</b>	152	BG2032P8M	254
<b>BG392P8M</b>	49	<b>BG840P8M</b>	105	<b>BG1248P8M</b>	156	<b>BG2064P8M</b>	258
<b>BG440P8M</b>	55	<b>BG848P8M</b>	106	<b>BG1264P8M</b>	158	BG2104P8M	263
<b>BG480P8M</b>	60	<b>BG856P8M</b>	107	<b>BG1280P8M</b>	160	<b>BG2160P8M</b>	270
<b>BG512P8M</b>	64	<b>BG880P8M</b>	110	<b>BG1304P8M</b>	163	<b>BG2240P8M</b>	280
<b>BG520P8M</b>	65	<b>BG896P8M</b>	112	<b>BG1320P8M</b>	165	<b>BG2256P8M</b>	282
<b>BG536P8M</b>	67	<b>BG912P8M</b>	114	<b>BG1344P8M</b>	168	BG2304P8M	288
<b>BG560P8M</b>	70	<b>BG920P8M</b>	115	<b>BG1352P8M</b>	169	<b>BG2320P8M</b>	290
BG576P8M	72	<b>BG936P8M</b>	117	<b>BG1360P8M</b>	170	<b>BG2400P8M</b>	300
<b>BG584P8M</b>	73	<b>BG944P8M</b>	118	<b>BG1400P8M</b>	175	<b>BG2456P8M</b>	307
<b>BG600P8M</b>	75	<b>BG960P8M</b>	120	<b>BG1424P8M</b>	178	<b>BG2496P8M</b>	312
<b>BG616P8M</b>	77	<b>BG984P8M</b>	123	<b>BG1440P8M</b>	180	<b>BG2600P8M</b>	325
<b>BG632P8M</b>	79	<b>BG1000P8M</b>	125	<b>BG1480P8M</b>	185	BG2712P8M	339
<b>BG640P8M</b>	80	<b>BG1032P8M</b>	129	<b>BG1520P8M</b>	190	BG2768P8M	346
<b>BG656P8M</b>	82	<b>BG1040P8M</b>	130	<b>BG1576P8M</b>	197	<b>BG2800P8M</b>	350
<b>BG680P8M</b>	85	<b>BG1056P8M</b>	132	<b>BG1600P8M</b>	200	BG2896P8M	362
BG688P8M	86	<b>BG1080P8M</b>	135	<b>BG1640P8M</b>	205	<b>BG2944P8M</b>	368
<b>BG712P8M</b>	89	<b>BG1096P8M</b>	137	<b>BG1680P8M</b>	210	<b>BG3048P8M</b>	381
<b>BG720P8M</b>	90	<b>BG1120P8M</b>	140	<b>BG1760P8M</b>	220	<b>BG3200P8M</b>	400
<b>BG752P8M</b>	94	<b>BG1128P8M</b>	141	<b>BG1800P8M</b>	225	<b>BG3304P8M</b>	413
<b>BG760P8M</b>	95	<b>BG1152P8M</b>	144	<b>BG1816P8M</b>	227	BG3440P8M	430
<b>BG776P8M</b>	97	<b>BG1160P8M</b>	145	<b>BG1888P8M</b>	236	<b>BG3600P8M</b>	450
<b>BG800P8M</b>	100	<b>BG1192P8M</b>	149	<b>BG1904P8M</b>	238	<b>BG3920P8M</b>	490
<b>BG816P8M</b>	102	<b>BG1200P8M</b>	150	<b>BG1960P8M</b>	245	<b>BG4400P8M</b>	550
BG824P8M	103	<b>BG1208P8M</b>	151	<b>BG2000P8M</b>	250		

· Bold Font : Stock item    Fine Font : Made to order, but in short lead time.

### ■ Pulley Dimensions (Reference)

No. of teeth	Pitch circle dia	Flange OD	No. of teeth	Pitch circle dia	Flange OD	No. of teeth	Pitch circle dia	Flange OD
<b>20</b>	50.93	55	<b>32</b>	81.49	86	<b>50</b>	127.32	135
<b>22</b>	56.02	62	<b>34</b>	86.58	91	<b>60</b>	152.79	158
<b>24</b>	61.12	66	<b>36</b>	91.67	97	<b>64</b>	162.97	170
<b>26</b>	66.21	73	<b>40</b>	101.86	107	<b>72</b>	183.35	190
<b>28</b>	71.30	79	<b>44</b>	112.05	119			
<b>30</b>	76.39	82	<b>48</b>	122.23	127			

 [Pulley Specifications](#) P54

## P14M (P : 14 mm)

### ■ Belt Tooth Profile and Dimensions

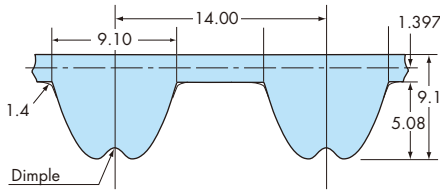

### ■ Model Identification

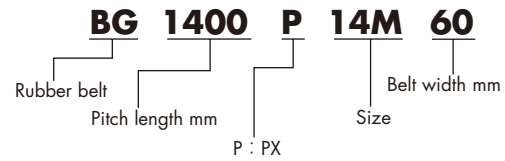

### ■ Materials

Rubber : Chloroprene rubber  
 Fabric : Nylon fabric  
 Cord : Fiberglass

### ■ Specifications and Characteristic

Pulley : PX Pulley P14M      Oil proof, Water proof : No ( Unusable )  
 Temperature Range : -15°C~+80°C      RoHS Directive : Compliance  
 Conductive property : No

### ■ Belt Width / Width Factor / Unit Mass / Installation Tension

Belt width mm	Belt width factor	Weight kg/m	Installation Tension N {kgf}	
			Recommended	Max. Value
40	1.00	0.393	990 {101.0}	1310 {134.0}
60	1.59	0.589	1500 {153.0}	2000 {204.0}
80	2.20	0.786	2110 {215.0}	2810 {286.0}
100	2.84	0.982	2710 {276.0}	3610 {368.0}
120	3.50	1.178	3340 {341.0}	4450 {454.0}

 Transmission Capacity Tables P33

 Selection and Design P39

### ■ Belt Length

Belt length	No. of teeth	Belt length	No. of teeth	Belt length	No. of teeth
<b>BG1120P14M</b>	80	<b>BG1960P14M</b>	140	<b>BG3850P14M</b>	275
BG1176P14M	84	<b>BG2002P14M</b>	143	<b>BG4004P14M</b>	286
<b>BG1190P14M</b>	85	<b>BG2100P14M</b>	150	BG4382P14M	313
<b>BG1246P14M</b>	89	BG2198P14M	157	<b>BG4508P14M</b>	322
<b>BG1344P14M</b>	96	<b>BG2240P14M</b>	160		
<b>BG1400P14M</b>	100	<b>BG2310P14M</b>	165		
BG1456P14M	104	<b>BG2380P14M</b>	170		
<b>BG1540P14M</b>	110	<b>BG2450P14M</b>	175		
<b>BG1610P14M</b>	115	<b>BG2590P14M</b>	185		
<b>BG1652P14M</b>	118	<b>BG2660P14M</b>	190		
<b>BG1680P14M</b>	120	<b>BG2800P14M</b>	200		
<b>BG1736P14M</b>	124	BG2940P14M	210		
<b>BG1778P14M</b>	127	<b>BG3150P14M</b>	225		
<b>BG1806P14M</b>	129	<b>BG3360P14M</b>	240		
<b>BG1890P14M</b>	135	<b>BG3500P14M</b>	250		

· Bold Font : Stock item    Fine Font : Made to order, but in short lead time.

### ■ Pulley Dimensions (Reference)

No. of teeth	Pitch circle dia	Flange OD	No. of teeth	Pitch circle dia	Flange OD	No. of teeth	Pitch circle dia	Flange OD
<b>28</b>	124.78	136	<b>38</b>	169.34	181	<b>50</b>	222.82	234
<b>30</b>	133.69	145	<b>40</b>	178.25	190	<b>56</b>	249.55	-
<b>32</b>	142.60	154	<b>42</b>	187.17	198	<b>60</b>	267.38	-
<b>34</b>	151.52	163	<b>44</b>	196.08	207	<b>64</b>	285.21	-
<b>36</b>	160.43	171	<b>48</b>	213.90	225	<b>72</b>	320.86	-

 Pulley Specifications P55





## P5M-W (P : 5 mm)

### ■ Belt Tooth Profile and Dimensions

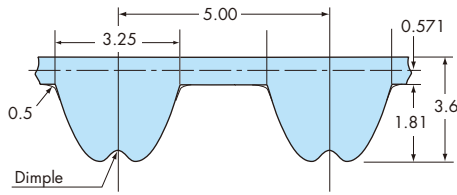

### ■ Model Identification

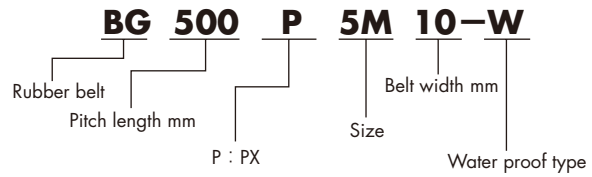

### ■ Materials

Rubber : Chloroprene rubber  
 Fabric : Nylon fabric  
 Cord : Aramid fiber

### ■ Specifications and Characteristic

Water proof : Usable in wet environment (Unusable in water)  
 Pulley : PX Pulley P5M Oil proof : No ( Unusable )  
 Temperature Range : -15°C~ +80°C RoHS Directive : Compliance  
 Conductive property : No

### ■ Belt Width / Width Factor / Unit Mass / Installation Tension

Belt width mm	Belt width factor	Weight kg/m	Installation Tension N {kgf}	
			Recommended	Max. Value
10	1.00	0.041	108 {11.0}	147 {15.0}
15	1.59	0.062	167 {17.0}	225 {23.0}
25	2.84	0.103	304 {31.0}	412 {42.0}

Transmission Capacity Tables P31

Selection and Design P39

### ■ Belt Length

Belt length	No. of teeth	Belt length	No. of teeth	Belt length	No. of teeth	Belt length	No. of teeth	Belt length	No. of teeth	Belt length	No. of teeth
BG215P5M	43	BG475P5M	95	BG650P5M	130	BG865P5M	173	BG1225P5M	245	BG2080P5M	416
BG225P5M	45	BG490P5M	98	BG670P5M	134	BG880P5M	176	BG1250P5M	250	BG2160P5M	432
BG255P5M	51	BG500P5M	100	BG675P5M	135	BG900P5M	180	BG1260P5M	252	BG2200P5M	440
BG260P5M	52	BG515P5M	103	BG690P5M	138	BG905P5M	181	BG1270P5M	254	BG2645P5M	529
BG275P5M	55	BG520P5M	104	BG695P5M	139	BG920P5M	184	BG1295P5M	259	BG3050P5M	610
BG295P5M	59	BG525P5M	105	BG700P5M	140	BG940P5M	188	BG1350P5M	270	BG3150P5M	630
BG300P5M	60	BG530P5M	106	BG710P5M	142	BG950P5M	190	BG1390P5M	278	BG3930P5M	786
BG310P5M	62	BG545P5M	109	BG725P5M	145	BG965P5M	193	BG1420P5M	284		
BG320P5M	64	BG550P5M	110	BG730P5M	146	BG985P5M	197	BG1490P5M	298		
BG325P5M	65	BG555P5M	111	BG740P5M	148	BG1000P5M	200	BG1530P5M	306		
BG340P5M	68	BG560P5M	112	BG750P5M	150	BG1025P5M	205	BG1550P5M	310		
BG350P5M	70	BG565P5M	113	BG765P5M	153	BG1050P5M	210	BG1595P5M	319		
BG370P5M	74	BG570P5M	114	BG770P5M	154	BG1060P5M	212	BG1615P5M	323		
BG375P5M	75	BG575P5M	115	BG775P5M	155	BG1090P5M	218	BG1675P5M	335		
BG400P5M	80	BG595P5M	119	BG780P5M	156	BG1125P5M	225	BG1700P5M	340		
BG420P5M	84	BG600P5M	120	BG800P5M	160	BG1150P5M	230	BG1800P5M	360		
BG425P5M	85	BG605P5M	121	BG810P5M	162	BG1160P5M	232	BG1870P5M	374		
BG430P5M	86	BG625P5M	125	BG830P5M	166	BG1180P5M	236	BG1910P5M	382		
BG440P5M	88	BG635P5M	127	BG835P5M	167	BG1195P5M	239	BG1960P5M	392		
BG450P5M	90	BG645P5M	129	BG850P5M	170	BG1220P5M	244	BG2000P5M	400		

· Made to order, but in short lead time.

### ■ Pulley Dimensions (Reference)

No. of teeth	Pitch circle dia	Flange OD	No. of teeth	Pitch circle dia	Flange OD	No. of teeth	Pitch circle dia	Flange OD	No. of teeth	Pitch circle dia	Flange OD
12	19.10	23	22	35.01	43	30	47.75	55	48	76.39	82
14	22.28	28	24	38.20	44	32	50.93	55	50	79.58	86
16	25.46	31	25	39.79	45	36	57.30	64	60	95.49	103
18	28.65	36	26	41.38	47	40	63.66	67	72	114.59	120
20	31.83	36	28	44.56	52	44	70.03	74			

Pulley Specifications P53



## P8M-W (P : 8 mm)

### ■ Belt Tooth Profile and Dimensions

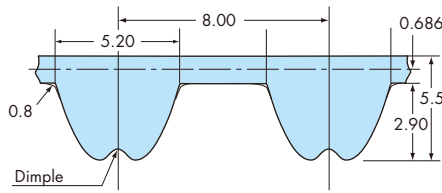

### ■ Model Identification

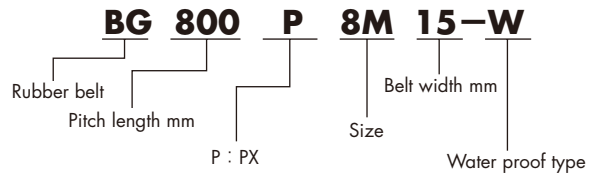

### ■ Materials

Rubber : Chloroprene rubber  
 Fabric : Nylon fabric  
 Cord : Aramid fiber

### ■ Specifications and Characteristic

Water proof : Usable in wet environment (Unusable in water)  
 Oil proof : No ( Unusable )  
 Temperature Range : -15°C ~ +80°C RoHS Directive : Compliance  
 Conductive property : No

### ■ Belt Width / Width Factor / Unit Mass / Installation Tension

Belt width mm	Belt width factor	Weight kg/m	Installation Tension N {kgf}	
			Recommended	Max. Value
15	1.00	0.084	225 {23.0}	294 {30.0}
25	1.79	0.139	382 {39.0}	510 {52.0}
40	3.06	0.223	657 {67.0}	860 {88.0}
60	4.86	0.334	1040 {106.0}	1370 {140.0}

Transmission Capacity Tables P32  
 Selection and Design P39

### ■ Belt Length

Belt length	No. of teeth	Belt length	No. of teeth	Belt length	No. of teeth	Belt length	No. of teeth	Belt length	No. of teeth	Belt length	No. of teeth
BG376P8M	47	BG712P8M	89	BG936P8M	117	BG1200P8M	150	BG1520P8M	190	BG2256P8M	282
BG392P8M	49	BG720P8M	90	BG944P8M	118	BG1208P8M	151	BG1576P8M	197	BG2320P8M	290
BG440P8M	55	BG752P8M	94	BG960P8M	120	BG1216P8M	152	BG1600P8M	200	BG2400P8M	300
BG480P8M	60	BG760P8M	95	BG984P8M	123	BG1248P8M	156	BG1640P8M	205	BG2456P8M	307
BG512P8M	64	BG776P8M	97	BG1000P8M	125	BG1264P8M	158	BG1680P8M	210	BG2496P8M	312
BG520P8M	65	BG800P8M	100	BG1032P8M	129	BG1280P8M	160	BG1760P8M	220	BG2600P8M	325
BG536P8M	67	BG816P8M	102	BG1040P8M	130	BG1304P8M	163	BG1800P8M	225	BG2800P8M	350
BG560P8M	70	BG832P8M	104	BG1056P8M	132	BG1320P8M	165	BG1816P8M	227	BG2944P8M	368
BG584P8M	73	BG840P8M	105	BG1080P8M	135	BG1344P8M	168	BG1888P8M	236	BG3048P8M	381
BG600P8M	75	BG848P8M	106	BG1096P8M	137	BG1352P8M	169	BG1904P8M	238	BG3200P8M	400
BG616P8M	77	BG856P8M	107	BG1120P8M	140	BG1360P8M	170	BG1960P8M	245	BG3304P8M	413
BG632P8M	79	BG880P8M	110	BG1128P8M	141	BG1400P8M	175	BG2000P8M	250	BG3600P8M	450
BG640P8M	80	BG896P8M	112	BG1152P8M	144	BG1424P8M	178	BG2064P8M	258	BG3920P8M	490
BG656P8M	82	BG912P8M	114	BG1160P8M	145	BG1440P8M	180	BG2160P8M	270	BG4400P8M	550
BG680P8M	85	BG920P8M	115	BG1192P8M	149	BG1480P8M	185	BG2240P8M	280		

· Made to order, but in short lead time.

### ■ Pulley Dimensions (Reference)

mm								
No. of teeth	Pitch circle dia	Flange OD	No. of teeth	Pitch circle dia	Flange OD	No. of teeth	Pitch circle dia	Flange OD
<b>20</b>	50.93	55	<b>32</b>	81.49	86	<b>50</b>	127.32	135
<b>22</b>	56.02	62	<b>34</b>	86.58	91	<b>60</b>	152.79	158
<b>24</b>	61.12	66	<b>36</b>	91.67	97	<b>64</b>	162.97	170
<b>26</b>	66.21	73	<b>40</b>	101.86	107	<b>72</b>	183.35	190
<b>28</b>	71.30	79	<b>44</b>	112.05	119			
<b>30</b>	76.39	82	<b>48</b>	122.23	127			

Pulley Specifications P54

## UP3M-HC (P : 3 mm)

### ■ Belt Tooth Profile and Dimensions

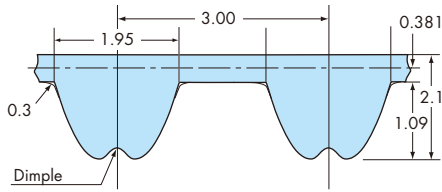

### ■ Model Identification

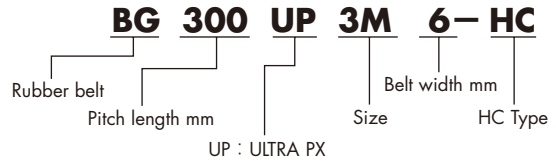

### ■ Materials

Rubber : High Intensity Chloroprene rubber  
 Fabric : Wear-resistant Fabric  
 Cord : High Intensity Fiberglass

### ■ Specifications and Characteristic

Pulley : PX Pulley P3M      Oil proof, Water proof : No ( Unusable )  
 Temperature Range : -15°C~+80°C      RoHS Directive : Compliance  
 Conductive property : No

### ■ Belt Width / Width Factor / Unit Mass / Installation Tension

Belt width mm	Belt width factor	Weight kg/m	Installation Tension N {kgf}	
			Recommended	Max. Value
6	1.00	0.013	29 {3.0}	40 {4.1}
10	1.78	0.022	54 {5.5}	72 {7.3}
15	2.84	0.034	88 {9.0}	118 {12.0}

Transmission Capacity Tables P34

Selection and Design P39

### ■ Belt Length

Belt length	No. of teeth	Belt length	No. of teeth	Belt length	No. of teeth	Belt length	No. of teeth	Belt length	No. of teeth	Belt length	No. of teeth
BG120UP3M	40	BG225UP3M	75	BG315UP3M	105	BG447UP3M	149	BG693UP3M	231	BG1041UP3M	347
BG123UP3M	41	BG228UP3M	76	BG318UP3M	106	BG450UP3M	150	BG699UP3M	233	BG1050UP3M	350
BG132UP3M	44	BG231UP3M	77	BG327UP3M	109	BG453UP3M	151	BG702UP3M	234	BG1059UP3M	353
BG138UP3M	46	BG234UP3M	78	BG330UP3M	110	BG459UP3M	153	BG705UP3M	235	BG1080UP3M	360
BG141UP3M	47	BG237UP3M	79	BG339UP3M	113	BG471UP3M	157	BG720UP3M	240	BG1110UP3M	370
BG144UP3M	48	BG240UP3M	80	BG342UP3M	114	BG477UP3M	159	BG738UP3M	246	BG1170UP3M	390
BG147UP3M	49	BG243UP3M	81	BG345UP3M	115	BG483UP3M	161	BG753UP3M	251	BG1191UP3M	397
BG150UP3M	50	BG246UP3M	82	BG351UP3M	117	BG486UP3M	162	BG756UP3M	252	BG1281UP3M	427
BG153UP3M	51	BG252UP3M	84	BG354UP3M	118	BG489UP3M	163	BG789UP3M	263	BG1305UP3M	435
BG159UP3M	53	BG255UP3M	85	BG360UP3M	120	BG501UP3M	167	BG804UP3M	268	BG1338UP3M	446
BG162UP3M	54	BG264UP3M	88	BG363UP3M	121	BG504UP3M	168	BG822UP3M	274	BG1344UP3M	448
BG171UP3M	57	BG267UP3M	89	BG369UP3M	123	BG507UP3M	169	BG852UP3M	284	BG1380UP3M	460
BG174UP3M	58	BG270UP3M	90	BG372UP3M	124	BG510UP3M	170	BG861UP3M	287	BG1443UP3M	481
BG177UP3M	59	BG273UP3M	91	BG378UP3M	126	BG525UP3M	175	BG870UP3M	290	BG1638UP3M	546
BG183UP3M	61	BG276UP3M	92	BG384UP3M	128	BG537UP3M	179	BG879UP3M	293	BG1689UP3M	563
BG186UP3M	62	BG279UP3M	93	BG387UP3M	129	BG552UP3M	184	BG885UP3M	295	BG1749UP3M	583
BG192UP3M	64	BG285UP3M	95	BG393UP3M	131	BG561UP3M	187	BG891UP3M	297	BG1893UP3M	631
BG195UP3M	65	BG288UP3M	96	BG399UP3M	133	BG588UP3M	196	BG918UP3M	306	BG1947UP3M	649
BG198UP3M	66	BG291UP3M	97	BG402UP3M	134	BG600UP3M	200	BG933UP3M	311		
BG201UP3M	67	BG294UP3M	98	BG405UP3M	135	BG618UP3M	206	BG948UP3M	316		
BG207UP3M	69	BG300UP3M	100	BG411UP3M	137	BG633UP3M	211	BG957UP3M	319		
BG210UP3M	70	BG303UP3M	101	BG420UP3M	140	BG660UP3M	220	BG972UP3M	324		
BG213UP3M	71	BG306UP3M	102	BG423UP3M	141	BG675UP3M	225	BG981UP3M	327		
BG219UP3M	73	BG309UP3M	103	BG432UP3M	144	BG681UP3M	227	BG1005UP3M	335		
BG222UP3M	74	BG312UP3M	104	BG438UP3M	146	BG687UP3M	229	BG1023UP3M	341		

· Made to order, but in short lead time.

### ■ Pulley Dimensions (Reference)

No. of teeth	Pitch circle dia	Flange OD	No. of teeth	Pitch circle dia	Flange OD	No. of teeth	Pitch circle dia	Flange OD	No. of teeth	Pitch circle dia	Flange OD
10	9.55	12	18	17.19	21	26	24.83	31	40	38.20	45
12	11.46	15	20	19.10	25	28	26.74	32	48	45.84	52
14	13.37	17	22	21.01	28	30	28.65	34	50	47.75	55
15	14.32	17	24	22.92	29	32	30.56	36	60	57.30	65
16	15.28	17	25	23.87	31	36	34.38	43			

Pulley Specifications P52



## UP5M-HC (P : 5 mm)

### ■ Belt Tooth Profile and Dimensions

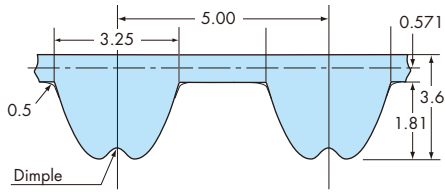

### ■ Model Identification

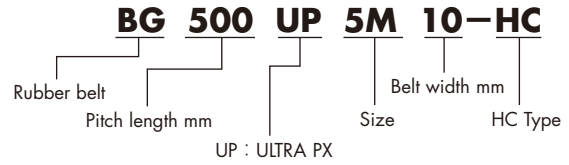

### ■ Materials

Rubber : High Intensity Chloroprene rubber  
 Fabric : Wear-resistant Fabric  
 Cord : High Intensity Fiberglass

### ■ Specifications and Characteristic

Pulley : PX Pulley P5M      Oil proof, Water proof : No ( Unusable )  
 Temperature Range : -15°C ~ +80°C      RoHS Directive : Compliance  
 Conductive property : No

### ■ Belt Width / Width Factor / Unit Mass / Installation Tension

Belt width mm	Belt width factor	Weight kg/m	Installation Tension N {kgf}	
			Recommended	Max. Value
10	1.00	0.041	108 {11.0}	147 {15.0}
15	1.59	0.062	167 {17.0}	225 {23.0}
25	2.84	0.103	304 {31.0}	412 {42.0}

Transmission Capacity Tables P35

Selection and Design P39

### ■ Belt Length

Belt length	No. of teeth	Belt length	No. of teeth	Belt length	No. of teeth	Belt length	No. of teeth	Belt length	No. of teeth
<b>BG175UP5M</b>	35	<b>BG490UP5M</b>	98	<b>BG695UP5M</b>	139	<b>BG1000UP5M</b>	200	BG1585UP5M	317
<b>BG215UP5M</b>	43	<b>BG500UP5M</b>	100	<b>BG700UP5M</b>	140	<b>BG1025UP5M</b>	205	<b>BG1595UP5M</b>	319
<b>BG225UP5M</b>	45	<b>BG515UP5M</b>	103	<b>BG710UP5M</b>	142	<b>BG1050UP5M</b>	210	<b>BG1615UP5M</b>	323
<b>BG255UP5M</b>	51	<b>BG520UP5M</b>	104	<b>BG725UP5M</b>	145	<b>BG1060UP5M</b>	212	<b>BG1675UP5M</b>	335
<b>BG260UP5M</b>	52	<b>BG525UP5M</b>	105	<b>BG730UP5M</b>	146	BG1080UP5M	216	<b>BG1700UP5M</b>	340
<b>BG275UP5M</b>	55	<b>BG530UP5M</b>	106	<b>BG740UP5M</b>	148	<b>BG1090UP5M</b>	218	<b>BG1800UP5M</b>	360
<b>BG295UP5M</b>	59	<b>BG545UP5M</b>	109	<b>BG750UP5M</b>	150	<b>BG1125UP5M</b>	225	<b>BG1870UP5M</b>	374
<b>BG300UP5M</b>	60	<b>BG550UP5M</b>	110	<b>BG765UP5M</b>	153	BG1145UP5M	229	<b>BG1910UP5M</b>	382
<b>BG310UP5M</b>	62	<b>BG555UP5M</b>	111	<b>BG770UP5M</b>	154	<b>BG1150UP5M</b>	230	<b>BG1960UP5M</b>	392
<b>BG320UP5M</b>	64	<b>BG560UP5M</b>	112	<b>BG775UP5M</b>	155	<b>BG1160UP5M</b>	232	<b>BG2000UP5M</b>	400
<b>BG325UP5M</b>	65	<b>BG565UP5M</b>	113	<b>BG780UP5M</b>	156	<b>BG1180UP5M</b>	236	BG2080UP5M	416
<b>BG340UP5M</b>	68	<b>BG570UP5M</b>	114	<b>BG800UP5M</b>	160	<b>BG1195UP5M</b>	239	BG2160UP5M	432
BG345UP5M	69	<b>BG575UP5M</b>	115	<b>BG810UP5M</b>	162	<b>BG1220UP5M</b>	244	BG2200UP5M	440
<b>BG350UP5M</b>	70	<b>BG595UP5M</b>	119	<b>BG830UP5M</b>	166	<b>BG1225UP5M</b>	245	BG2455UP5M	491
<b>BG370UP5M</b>	74	<b>BG600UP5M</b>	120	<b>BG835UP5M</b>	167	<b>BG1250UP5M</b>	250	BG2645UP5M	529
<b>BG375UP5M</b>	75	<b>BG605UP5M</b>	121	<b>BG850UP5M</b>	170	<b>BG1260UP5M</b>	252	BG2725UP5M	545
BG390UP5M	78	<b>BG625UP5M</b>	125	<b>BG865UP5M</b>	173	<b>BG1270UP5M</b>	254	BG2795UP5M	559
<b>BG400UP5M</b>	80	<b>BG635UP5M</b>	127	<b>BG880UP5M</b>	176	<b>BG1295UP5M</b>	259	BG3050UP5M	610
<b>BG420UP5M</b>	84	BG640UP5M	128	<b>BG900UP5M</b>	180	<b>BG1350UP5M</b>	270	BG3150UP5M	630
<b>BG425UP5M</b>	85	<b>BG645UP5M</b>	129	<b>BG905UP5M</b>	181	<b>BG1390UP5M</b>	278	BG3930UP5M	786
<b>BG430UP5M</b>	86	<b>BG650UP5M</b>	130	<b>BG920UP5M</b>	184	<b>BG1420UP5M</b>	284		
<b>BG440UP5M</b>	88	<b>BG670UP5M</b>	134	<b>BG940UP5M</b>	188	<b>BG1490UP5M</b>	298		
<b>BG450UP5M</b>	90	<b>BG675UP5M</b>	135	<b>BG950UP5M</b>	190	BG1495UP5M	299		
BG470UP5M	94	BG680UP5M	136	<b>BG965UP5M</b>	193	<b>BG1530UP5M</b>	306		
<b>BG475UP5M</b>	95	<b>BG690UP5M</b>	138	<b>BG985UP5M</b>	197	<b>BG1550UP5M</b>	310		

· Bold Font : Stock item    Fine Font : Made to order, but in short lead time.

### ■ Pulley Dimensions (Reference)

No. of teeth	Pitch circle dia	Flange OD	No. of teeth	Pitch circle dia	Flange OD	No. of teeth	Pitch circle dia	Flange OD	No. of teeth	Pitch circle dia	Flange OD
<b>12</b>	19.10	23	<b>22</b>	35.01	43	<b>30</b>	47.75	55	<b>48</b>	76.39	82
<b>14</b>	22.28	28	<b>24</b>	38.20	44	<b>32</b>	50.93	55	<b>50</b>	79.58	86
<b>16</b>	25.46	31	<b>25</b>	39.79	45	<b>36</b>	57.30	64	<b>60</b>	95.49	103
<b>18</b>	28.65	36	<b>26</b>	41.38	47	<b>40</b>	63.66	67	<b>72</b>	114.59	120
<b>20</b>	31.83	36	<b>28</b>	44.56	52	<b>44</b>	70.03	74			

Pulley Specifications P53



## UP8M-HC (P : 8 mm)

### ■ Belt Tooth Profile and Dimensions

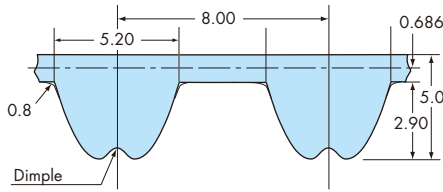

### ■ Model Identification

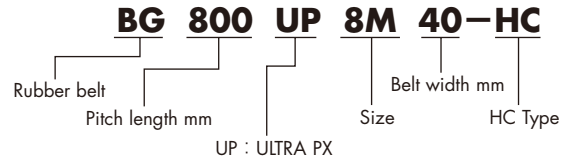

### ■ Materials

Rubber : High Intensity Synthetic rubber ( blue )  
 Fabric : Wear-resistant Fabric  
 Cord : High Intensity Fiberglass

### ■ Specifications and Characteristic

Pulley : PX Pulley P8M Oil proof, Water proof : No ( Unusable )  
 Temperature Range : -15°C ~ +80°C RoHS Directive : Compliance  
 Conductive property : No

### ■ Belt Width / Width Factor / Unit Mass / Installation Tension

Belt width mm	Belt width factor	Weight kg/m	Installation Tension N {kgf}	
			Recommended	Max. Value
15	1.00	0.076	177 {18.0}	235 {24.0}
25	1.79	0.127	304 {31.0}	408 {41.6}
40	3.06	0.203	530 {54.0}	690 {70.4}
60	4.86	0.304	834 {85.0}	1100 {112.0}

Transmission Capacity Tables P36  
 Selection and Design P39

### ■ Belt Length

Belt length	No. of teeth	Belt length	No. of teeth	Belt length	No. of teeth	Belt length	No. of teeth
<b>BG480UP8M</b>	60	<b>BG856UP8M</b>	107	<b>BG1280UP8M</b>	160	BG2160UP8M	270
<b>BG512UP8M</b>	64	<b>BG880UP8M</b>	110	<b>BG1304UP8M</b>	163	BG2240UP8M	280
<b>BG520UP8M</b>	65	<b>BG896UP8M</b>	112	<b>BG1320UP8M</b>	165	BG2256UP8M	282
<b>BG536UP8M</b>	67	<b>BG912UP8M</b>	114	<b>BG1344UP8M</b>	168	BG2304UP8M	288
<b>BG560UP8M</b>	70	<b>BG920UP8M</b>	115	<b>BG1352UP8M</b>	169	BG2320UP8M	290
BG576UP8M	72	<b>BG936UP8M</b>	117	<b>BG1360UP8M</b>	170	BG2400UP8M	300
<b>BG584UP8M</b>	73	<b>BG944UP8M</b>	118	<b>BG1400UP8M</b>	175	BG2456UP8M	307
<b>BG600UP8M</b>	75	<b>BG960UP8M</b>	120	<b>BG1424UP8M</b>	178	BG2496UP8M	312
<b>BG616UP8M</b>	77	<b>BG984UP8M</b>	123	<b>BG1440UP8M</b>	180	BG2600UP8M	325
<b>BG632UP8M</b>	79	<b>BG1000UP8M</b>	125	<b>BG1480UP8M</b>	185	BG2712UP8M	339
<b>BG640UP8M</b>	80	<b>BG1032UP8M</b>	129	<b>BG1520UP8M</b>	190	BG2768UP8M	346
<b>BG656UP8M</b>	82	<b>BG1040UP8M</b>	130	<b>BG1576UP8M</b>	197	BG2800UP8M	350
<b>BG680UP8M</b>	85	<b>BG1056UP8M</b>	132	<b>BG1600UP8M</b>	200	BG2896UP8M	362
BG688UP8M	86	<b>BG1080UP8M</b>	135	<b>BG1640UP8M</b>	205	BG2944UP8M	368
<b>BG712UP8M</b>	89	<b>BG1096UP8M</b>	137	<b>BG1680UP8M</b>	210	BG3048UP8M	381
<b>BG720UP8M</b>	90	<b>BG1120UP8M</b>	140	<b>BG1760UP8M</b>	220	BG3200UP8M	400
<b>BG752UP8M</b>	94	<b>BG1128UP8M</b>	141	<b>BG1800UP8M</b>	225	BG3304UP8M	413
<b>BG760UP8M</b>	95	<b>BG1152UP8M</b>	144	<b>BG1816UP8M</b>	227	BG3440UP8M	430
<b>BG776UP8M</b>	97	<b>BG1160UP8M</b>	145	<b>BG1888UP8M</b>	236	BG3600UP8M	450
<b>BG800UP8M</b>	100	<b>BG1192UP8M</b>	149	<b>BG1904UP8M</b>	238	BG3920UP8M	490
<b>BG816UP8M</b>	102	<b>BG1200UP8M</b>	150	<b>BG1960UP8M</b>	245	BG4400UP8M	550
BG824UP8M	103	<b>BG1208UP8M</b>	151	<b>BG2000UP8M</b>	250		
<b>BG832UP8M</b>	104	<b>BG1216UP8M</b>	152	BG2032UP8M	254		
<b>BG840UP8M</b>	105	<b>BG1248UP8M</b>	156	BG2064UP8M	258		
<b>BG848UP8M</b>	106	<b>BG1264UP8M</b>	158	BG2104UP8M	263		

· Both bold font and belt width 15mm, 25mm, 40mm : Stock item Both fine font and belt width 60mm : Made to order, but in short lead time.

### ■ Pulley Dimensions (Reference)

No. of teeth	Pitch circle dia	Flange OD	No. of teeth	Pitch circle dia	Flange OD	No. of teeth	Pitch circle dia	Flange OD
<b>20</b>	50.93	55	<b>32</b>	81.49	86	<b>50</b>	127.32	135
<b>22</b>	56.02	62	<b>34</b>	86.58	91	<b>60</b>	152.79	158
<b>24</b>	61.12	66	<b>36</b>	91.67	97	<b>64</b>	162.97	170
<b>26</b>	66.21	73	<b>40</b>	101.86	107	<b>72</b>	183.35	190
<b>28</b>	71.30	79	<b>44</b>	112.05	119			
<b>30</b>	76.39	82	<b>48</b>	122.23	127			

Pulley Specifications P54



## UP14M-HC (P : 14 mm)

### ■ Belt Tooth Profile and Dimensions

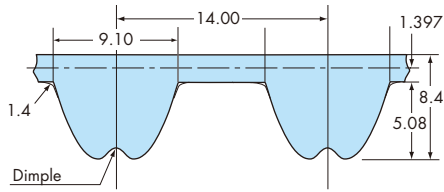

### ■ Model Identification

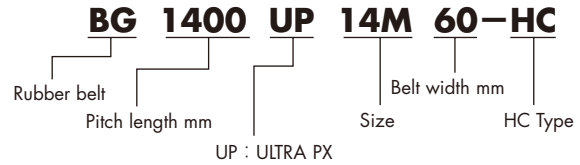

### ■ Materials

Rubber : High Intensity Synthetic rubber ( blue )  
 Fabric : Wear-resistant Fabric  
 Cord : High Intensity Fiberglass

### ■ Specifications and Characteristic

Pulley : PX Pulley P14M      Oil proof, Water proof : No ( Unusable )  
 Temperature Range : -15°C ~ +80°C      RoHS Directive : Compliance  
 Conductive property : No

### ■ Belt Width / Width Factor / Unit Mass / Installation Tension

Belt width mm	Belt width factor	Weight kg/m	Installation Tension N {kgf}	
			Recommended	Max. Value
40	1.00	0.304	794 {81.0}	1050 {107.0}
60	1.59	0.456	1200 {122.0}	1600 {163.0}
80	2.20	0.608	1690 {172.0}	2250 {229.0}
100	2.84	0.760	2170 {221.0}	2880 {294.0}
120	3.50	0.912	2680 {273.0}	3560 {363.0}

Transmission Capacity Tables P37

Selection and Design P39

### ■ Belt Length

Belt length	No. of teeth	Belt length	No. of teeth	Belt length	No. of teeth
<b>BG1120UP14M</b>	80	<b>BG1960UP14M</b>	140	BG3850UP14M	275
BG1176UP14M	84	BG2002UP14M	143	BG4004UP14M	286
<b>BG1190UP14M</b>	85	BG2100UP14M	150	BG4382UP14M	313
<b>BG1246UP14M</b>	89	BG2198UP14M	157	BG4508UP14M	322
<b>BG1344UP14M</b>	96	BG2240UP14M	160		
<b>BG1400UP14M</b>	100	BG2310UP14M	165		
BG1456UP14M	104	BG2380UP14M	170		
<b>BG1540UP14M</b>	110	BG2450UP14M	175		
<b>BG1610UP14M</b>	115	BG2590UP14M	185		
<b>BG1652UP14M</b>	118	BG2660UP14M	190		
<b>BG1680UP14M</b>	120	BG2800UP14M	200		
<b>BG1736UP14M</b>	124	BG2940UP14M	210		
<b>BG1778UP14M</b>	127	BG3150UP14M	225		
<b>BG1806UP14M</b>	129	BG3360UP14M	240		
<b>BG1890UP14M</b>	135	BG3500UP14M	250		

· Both bold font and belt width 40mm, 60mm : Stock item    Both fine font and belt width 80mm, 100mm, 120mm : Made to order, but in short lead time.

### ■ Pulley Dimensions (Reference)

No. of teeth	Pitch circle dia	Flange OD	No. of teeth	Pitch circle dia	Flange OD	No. of teeth	Pitch circle dia	Flange OD
<b>28</b>	124.78	136	<b>38</b>	169.34	181	<b>50</b>	222.82	234
<b>30</b>	133.69	145	<b>40</b>	178.25	190	<b>56</b>	249.55	-
<b>32</b>	142.60	154	<b>42</b>	187.17	198	<b>60</b>	267.38	-
<b>34</b>	151.52	163	<b>44</b>	196.08	207	<b>64</b>	285.21	-
<b>36</b>	160.43	171	<b>48</b>	213.90	225	<b>72</b>	320.86	-

Pulley Specifications P55



### UP5M-HA (P : 5mm)

#### ■ Belt Tooth Profile and Dimensions

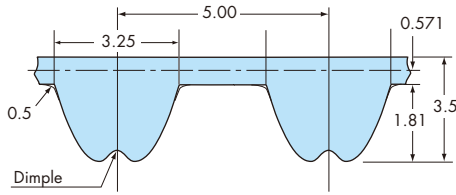

#### ■ Model Identification

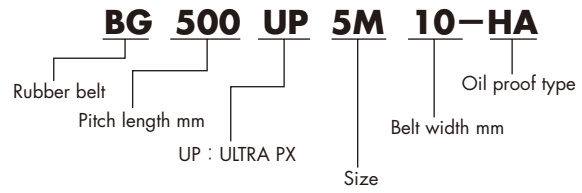

#### ■ Materials

Rubber : High Intensity Synthetic rubber ( Oil proof Specification )  
 Fabric : Wear-resistant Fabric  
 Cord : High Intensity Fiberglass

#### ■ Specifications and Characteristic

Oil proof, Water proof : Available in oil or water ( Included water solubility coolant liquid ) environment  
 Pulley : PX Pulley P5M RoHS Directive : Compliance  
 Temperature Range : 0°C ~ 60°C ( In oil environment )  
 Conductive property : No  
 \*Available for heat-resistant use. Please inquire about us for more information.

#### ■ Belt Width / Width Factor / Unit Mass / Installation Tension

Belt width mm	Belt width factor	Weight kg/m	Installation Tension N {kgf}	
			Recommended	Max. Value
10	1.00	0.034	108 {11.0}	147 {15.0}
15	1.59	0.050	167 {17.0}	225 {23.0}
25	2.84	0.084	304 {31.0}	412 {42.0}

Transmission Capacity Tables P35

Selection and Design P39

#### ■ Belt Length

Belt length	No. of teeth	Belt length	No. of teeth	Belt length	No. of teeth	Belt length	No. of teeth
BG475UP5M	95	BG700UP5M	140	BG1025UP5M	205	BG1800UP5M	360
BG490UP5M	98	BG710UP5M	142	BG1050UP5M	210	BG1870UP5M	374
BG500UP5M	100	BG725UP5M	145	BG1060UP5M	212	BG1910UP5M	382
BG515UP5M	103	BG730UP5M	146	BG1090UP5M	218	BG1960UP5M	392
BG520UP5M	104	BG740UP5M	148	BG1125UP5M	225	BG2000UP5M	400
BG525UP5M	105	BG750UP5M	150	BG1150UP5M	230	BG2080UP5M	416
BG530UP5M	106	BG765UP5M	153	BG1160UP5M	232	BG2160UP5M	432
BG545UP5M	109	BG770UP5M	154	BG1180UP5M	236	BG2200UP5M	440
BG550UP5M	110	BG775UP5M	155	BG1195UP5M	239	BG2645UP5M	529
BG555UP5M	111	BG780UP5M	156	BG1220UP5M	244	BG3050UP5M	610
BG560UP5M	112	BG800UP5M	160	BG1225UP5M	245	BG3150UP5M	630
BG565UP5M	113	BG810UP5M	162	BG1250UP5M	250	BG3930UP5M	786
BG570UP5M	114	BG830UP5M	166	BG1260UP5M	252		
BG575UP5M	115	BG835UP5M	167	BG1270UP5M	254		
BG595UP5M	119	BG850UP5M	170	BG1295UP5M	259		
BG600UP5M	120	BG865UP5M	173	BG1350UP5M	270		
BG605UP5M	121	BG880UP5M	176	BG1390UP5M	278		
BG625UP5M	125	BG900UP5M	180	BG1420UP5M	284		
BG635UP5M	127	BG905UP5M	181	BG1490UP5M	298		
BG645UP5M	129	BG920UP5M	184	BG1530UP5M	306		
BG650UP5M	130	BG940UP5M	188	BG1550UP5M	310		
BG670UP5M	134	BG950UP5M	190	BG1595UP5M	319		
BG675UP5M	135	BG965UP5M	193	BG1615UP5M	323		
BG690UP5M	138	BG985UP5M	197	BG1675UP5M	335		
BG695UP5M	139	BG1000UP5M	200	BG1700UP5M	340		

· Made to order, but in short lead time.

#### ■ Pulley Dimensions (Reference)

No. of teeth	Pitch circle dia	Flange OD	No. of teeth	Pitch circle dia	Flange OD	No. of teeth	Pitch circle dia	Flange OD	No. of teeth	Pitch circle dia	Flange OD
12	19.10	23	22	35.01	43	30	47.75	55	48	76.39	82
14	22.28	28	24	38.20	44	32	50.93	55	50	79.58	86
16	25.46	31	25	39.79	45	36	57.30	64	60	95.49	103
18	28.65	36	26	41.38	47	40	63.66	67	72	114.59	120
20	31.83	36	28	44.56	52	44	70.03	74			

Pulley Specifications P53



## UP8M-HA (P : 8 mm)

### ■ Belt Tooth Profile and Dimensions

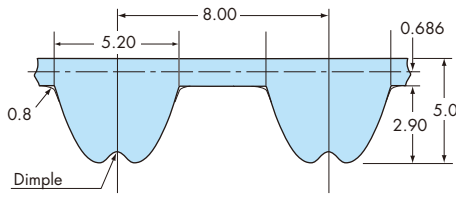

### ■ Model Identification

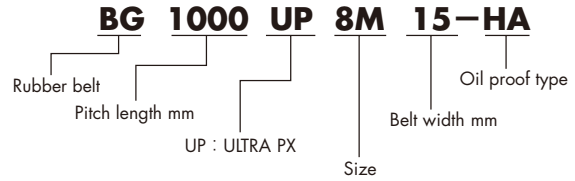

### ■ Materials

Rubber : High Intensity Synthetic rubber ( Oil proof Specification )  
 Fabric : Wear-resistant Fabric  
 Cord : High Intensity Fiberglass

### ■ Specifications and Characteristic

Oil proof, Water proof : Available in oil or water ( Included water solubility coolant liquid ) environment  
 Pulley : PX Pulley P8M      RoHS Directive : Compliance  
 Temperature Range : 0°C ~ 60°C ( In oil environment )  
 Conductive property : No  
 \*Available for heat-resistant use. Please inquire about us for more information.

### ■ Belt Width / Width Factor / Unit Mass / Installation Tension

Belt width mm	Belt width factor	Weight kg/m	Installation Tension N {kgf}	
			Recommended	Max. Value
15	1.00	0.070	177 {18.0}	235 {24.0}
25	1.79	0.117	304 {31.0}	408 {41.6}
40	3.06	0.187	530 {54.0}	690 {70.4}
60	4.86	0.281	834 {85.0}	1100 {112}

- Transmission Capacity Tables P36
- Selection and Design P39

### ■ Belt Length

Belt length	No. of teeth	Belt length	No. of teeth	Belt length	No. of teeth	Belt length	No. of teeth
BG480UP8M	60	BG912UP8M	114	BG1344UP8M	168	BG2456UP8M	307
BG512UP8M	64	BG920UP8M	115	BG1352UP8M	169	BG2496UP8M	312
BG520UP8M	65	BG936UP8M	117	BG1360UP8M	170	BG2600UP8M	325
BG536UP8M	67	BG944UP8M	118	BG1400UP8M	175	BG2800UP8M	350
BG560UP8M	70	BG960UP8M	120	BG1424UP8M	178	BG2944UP8M	368
BG584UP8M	73	BG984UP8M	123	BG1440UP8M	180	BG3048UP8M	381
BG600UP8M	75	BG1000UP8M	125	BG1480UP8M	185	BG3200UP8M	400
BG616UP8M	77	BG1032UP8M	129	BG1520UP8M	190	BG3304UP8M	413
BG632UP8M	79	BG1040UP8M	130	BG1576UP8M	197	BG3600UP8M	450
BG640UP8M	80	BG1056UP8M	132	BG1600UP8M	200	BG3920UP8M	490
BG656UP8M	82	BG1080UP8M	135	BG1640UP8M	205	BG4400UP8M	550
BG680UP8M	85	BG1096UP8M	137	BG1680UP8M	210		
BG712UP8M	89	BG1120UP8M	140	BG1760UP8M	220		
BG720UP8M	90	BG1128UP8M	141	BG1800UP8M	225		
BG752UP8M	94	BG1152UP8M	144	BG1816UP8M	227		
BG760UP8M	95	BG1160UP8M	145	BG1888UP8M	236		
BG776UP8M	97	BG1192UP8M	149	BG1904UP8M	238		
BG800UP8M	100	BG1200UP8M	150	BG1960UP8M	245		
BG816UP8M	102	BG1208UP8M	151	BG2000UP8M	250		
BG832UP8M	104	BG1216UP8M	152	BG2064UP8M	258		
BG840UP8M	105	BG1248UP8M	156	BG2160UP8M	270		
BG848UP8M	106	BG1264UP8M	158	BG2240UP8M	280		
BG856UP8M	107	BG1280UP8M	160	BG2256UP8M	282		
BG880UP8M	110	BG1304UP8M	163	BG2320UP8M	290		
BG896UP8M	112	BG1320UP8M	165	BG2400UP8M	300		

· Made to order, but in short lead time.

### ■ Pulley Dimensions (Reference)

No. of teeth	Pitch circle dia	Flange OD	No. of teeth	Pitch circle dia	Flange OD	No. of teeth	Pitch circle dia	Flange OD
<b>20</b>	50.93	55	<b>32</b>	81.49	86	<b>50</b>	127.32	135
<b>22</b>	56.02	62	<b>34</b>	86.58	91	<b>60</b>	152.79	158
<b>24</b>	61.12	66	<b>36</b>	91.67	97	<b>64</b>	162.97	170
<b>26</b>	66.21	73	<b>40</b>	101.86	107	<b>72</b>	183.35	190
<b>28</b>	71.30	79	<b>44</b>	112.05	119			
<b>30</b>	76.39	82	<b>48</b>	122.23	127			

- Pulley Specifications P54





## UP3M-HY (P : 3 mm)

### ■ Belt Tooth Profile and Dimensions

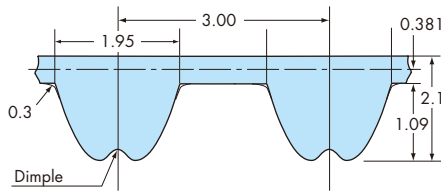

### ■ Model Identification

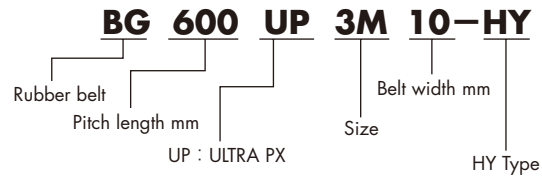

### ■ Materials

Rubber : High Intensity Chloroprene rubber  
 Fabric : Wear-resistant Fabric  
 Cord : Hybrid of carbon fiber and high intensity fiberglass

### ■ Specifications and Characteristic

Pulley : PX Pulley P3M      Oil proof, Water proof : No ( Unusable )  
 Temperature Range : -15°C~ +80°C      RoHS Directive : Compliance  
 Conductive property : No

### ■ Belt Width / Width Factor / Unit Mass / Installation Tension

Belt width mm	Belt width factor	Weight kg/m	Installation Tension N {kgf}	
			Recommended	Max. Value
6	1.00	0.016	39 {4.0}	47 {4.8}
10	1.74	0.026	67 {6.8}	80 {8.2}
15	2.69	0.039	104 {10.6}	125 {12.8}

Please inquire about us for transmission capacity and selection.

### ■ Belt Length

Belt length	No. of teeth	Belt length	No. of teeth	Belt length	No. of teeth	Belt length	No. of teeth
BG312UP3M	104	BG459UP3M	153	BG738UP3M	246	BG1338UP3M	446
BG318UP3M	106	BG477UP3M	159	BG753UP3M	251	BG1344UP3M	448
BG330UP3M	110	BG483UP3M	161	BG756UP3M	252	BG1380UP3M	460
BG339UP3M	113	BG486UP3M	162	BG789UP3M	263	BG1443UP3M	481
BG345UP3M	115	BG489UP3M	163	BG804UP3M	268	BG1638UP3M	546
BG354UP3M	118	BG501UP3M	167	BG852UP3M	284	BG1689UP3M	563
BG360UP3M	120	BG504UP3M	168	BG861UP3M	287	BG1749UP3M	583
BG363UP3M	121	BG507UP3M	169	BG879UP3M	293	BG1893UP3M	631
BG369UP3M	123	BG510UP3M	170	BG891UP3M	297	BG1947UP3M	649
BG372UP3M	124	BG525UP3M	175	BG918UP3M	306		
BG378UP3M	126	BG537UP3M	179	BG933UP3M	311		
BG384UP3M	128	BG552UP3M	184	BG948UP3M	316		
BG387UP3M	129	BG561UP3M	187	BG957UP3M	319		
BG393UP3M	131	BG588UP3M	196	BG972UP3M	324		
BG399UP3M	133	BG600UP3M	200	BG1005UP3M	335		
BG402UP3M	134	BG633UP3M	211	BG1023UP3M	341		
BG405UP3M	135	BG660UP3M	220	BG1041UP3M	347		
BG411UP3M	137	BG675UP3M	225	BG1050UP3M	350		
BG420UP3M	140	BG681UP3M	227	BG1059UP3M	353		
BG423UP3M	141	BG687UP3M	229	BG1080UP3M	360		
BG432UP3M	144	BG693UP3M	231	BG1110UP3M	370		
BG438UP3M	146	BG699UP3M	233	BG1170UP3M	390		
BG447UP3M	149	BG702UP3M	234	BG1191UP3M	397		
BG450UP3M	150	BG705UP3M	235	BG1281UP3M	427		
BG453UP3M	151	BG720UP3M	240	BG1305UP3M	435		

· Made to order Lot sales items, Please inquire about us for the number of lots.

### ■ Pulley Dimensions (Reference)

mm											
No. of teeth	Pitch circle dia	Flange OD	No. of teeth	Pitch circle dia	Flange OD	No. of teeth	Pitch circle dia	Flange OD	No. of teeth	Pitch circle dia	Flange OD
10	9.55	12	18	17.19	21	26	24.83	31	40	38.20	45
12	11.46	15	20	19.10	25	28	26.74	32	48	45.84	52
14	13.37	17	22	21.01	28	30	28.65	34	50	47.75	55
15	14.32	17	24	22.92	29	32	30.56	36	60	57.30	65
16	15.28	17	25	23.87	31	36	34.38	43			



## UP5M-HY (P : 5 mm)

### ■ Belt Tooth Profile and Dimensions

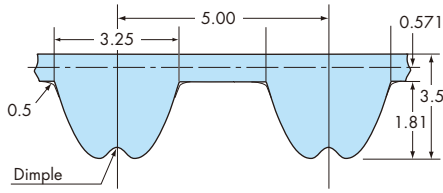

### ■ Model Identification

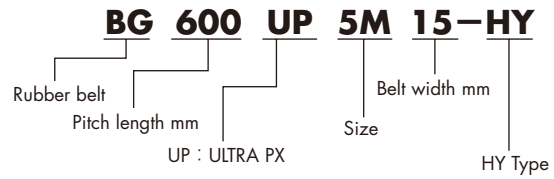

### ■ Materials

Rubber : High Intensity Synthetic rubber  
 Fabric : Wear-resistant Fabric  
 Cord : Hybrid of carbon fiber and high intensity fiberglass

### ■ Specifications and Characteristic

Pulley : PX Pulley P5M  
 Oil proof, Water proof : No ( Unusable )  
 Temperature Range : -15°C~ +80°C RoHS Directive : Compliance  
 Conductive property : No

### ■ Belt Width / Width Factor / Unit Mass / Installation Tension

Belt width mm	Belt width factor	Weight kg/m	Installation Tension N {kgf}	
			Recommended	Max. Value
10	1.00	0.035	125 {12.8}	165 {16.8}
15	1.55	0.053	200 {20.4}	260 {26.5}
25	2.69	0.088	355 {36.2}	460 {46.9}

Please inquire about us for transmission capacity and selection.

### ■ Belt Length

Belt length	No. of teeth	Belt length	No. of teeth	Belt length	No. of teeth
BG600UP5M	120	BG950UP5M	190	BG1530UP5M	306
BG635UP5M	127	BG965UP5M	193	BG1550UP5M	310
BG645UP5M	129	BG985UP5M	197	BG1595UP5M	319
BG650UP5M	130	BG1000UP5M	200	BG1615UP5M	323
BG690UP5M	138	BG1025UP5M	205	BG1675UP5M	335
BG695UP5M	139	BG1050UP5M	210	BG1700UP5M	340
BG700UP5M	140	BG1060UP5M	212	BG1800UP5M	360
BG710UP5M	142	BG1080UP5M	216	BG1870UP5M	374
BG725UP5M	145	BG1090UP5M	218	BG1910UP5M	382
BG730UP5M	146	BG1125UP5M	225	BG1960UP5M	392
BG740UP5M	148	BG1145UP5M	229	BG2000UP5M	400
BG750UP5M	150	BG1150UP5M	230	BG2080UP5M	416
BG765UP5M	153	BG1160UP5M	232	BG2160UP5M	432
BG780UP5M	156	BG1180UP5M	236	BG2200UP5M	440
BG800UP5M	160	BG1195UP5M	239	BG2645UP5M	529
BG810UP5M	162	BG1220UP5M	244	BG3050UP5M	610
BG830UP5M	166	BG1225UP5M	245	BG3150UP5M	630
BG835UP5M	167	BG1250UP5M	250	BG3930UP5M	786
BG850UP5M	170	BG1260UP5M	252		
BG865UP5M	173	BG1270UP5M	254		
BG880UP5M	176	BG1295UP5M	259		
BG900UP5M	180	BG1350UP5M	270		
BG905UP5M	181	BG1390UP5M	278		
BG920UP5M	184	BG1420UP5M	284		
BG940UP5M	188	BG1490UP5M	298		

· Made to order Lot sales items, Please inquire about us for the number of lots.

### ■ Pulley Dimensions (Reference)

No. of teeth	Pitch circle dia	Flange OD	No. of teeth	Pitch circle dia	Flange OD	No. of teeth	Pitch circle dia	Flange OD	No. of teeth	Pitch circle dia	Flange OD
12	19.10	23	22	35.01	43	30	47.75	55	48	76.39	82
14	22.28	28	24	38.20	44	32	50.93	55	50	79.58	86
16	25.46	31	25	39.79	45	36	57.30	64	60	95.49	103
18	28.65	36	26	41.38	47	40	63.66	67	72	114.59	120
20	31.83	36	28	44.56	52	44	70.03	74			



## UP8M-HY (P : 8 mm)

### ■ Belt Tooth Profile and Dimensions

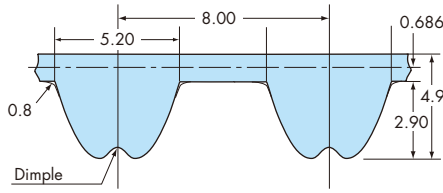

### ■ Model Identification

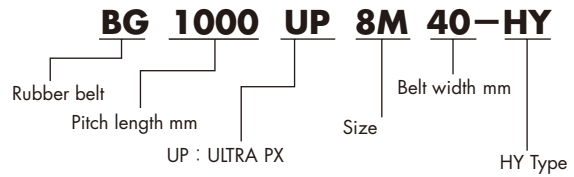

### ■ Materials

Rubber : High Intensity Synthetic rubber (Gray)  
 Fabric : Wear-resistant Fabric  
 Cord : Hybrid of carbon fiber and high intensity fiberglass

### ■ Specifications and Characteristic

Pulley : PX Pulley P8M      Oil proof, Water proof : No ( Unusable )  
 Temperature Range : -15°C~ +80°C      RoHS Directive : Compliance  
 Conductive property : No

### ■ Belt Width / Width Factor / Unit Mass / Installation Tension

Belt width mm	Belt width factor	Weight kg/m	Installation Tension N {kgf}	
			Recommended	Max. Value
15	1.00	0.068	255 {26.0}	290 {29.6}
25	1.74	0.113	445 {45.4}	510 {52.0}
40	2.91	0.180	730 {74.4}	840 {85.7}
60	4.52	0.270	1120 {114.2}	1290 {131.6}

Please inquire about us for transmission capacity and selection.

### ■ Belt Length

Belt length	No. of teeth	Belt length	No. of teeth	Belt length	No. of teeth
BG760UP8M	95	BG1160UP8M	145	BG1888UP8M	236
BG776UP8M	97	BG1192UP8M	149	BG1904UP8M	238
BG800UP8M	100	BG1200UP8M	150	BG1960UP8M	245
BG816UP8M	102	BG1208UP8M	151	BG2000UP8M	250
BG832UP8M	104	BG1216UP8M	152	BG2064UP8M	258
BG840UP8M	105	BG1248UP8M	156	BG2160UP8M	270
BG848UP8M	106	BG1264UP8M	158	BG2240UP8M	280
BG856UP8M	107	BG1280UP8M	160	BG2256UP8M	282
BG880UP8M	110	BG1304UP8M	163	BG2320UP8M	290
BG896UP8M	112	BG1320UP8M	165	BG2400UP8M	300
BG912UP8M	114	BG1344UP8M	168	BG2456UP8M	307
BG920UP8M	115	BG1352UP8M	169	BG2496UP8M	312
BG936UP8M	117	BG1360UP8M	170	BG2600UP8M	325
BG944UP8M	118	BG1400UP8M	175	BG2800UP8M	350
BG960UP8M	120	BG1424UP8M	178	BG2944UP8M	368
BG984UP8M	123	BG1440UP8M	180	BG3048UP8M	381
BG1000UP8M	125	BG1480UP8M	185	BG3200UP8M	400
BG1032UP8M	129	BG1520UP8M	190	BG3304UP8M	413
BG1040UP8M	130	BG1576UP8M	197	BG3600UP8M	450
BG1056UP8M	132	BG1600UP8M	200	BG3920UP8M	490
BG1080UP8M	135	BG1640UP8M	205	BG4400UP8M	550
BG1096UP8M	137	BG1680UP8M	210		
BG1120UP8M	140	BG1760UP8M	220		
BG1128UP8M	141	BG1800UP8M	225		
BG1152UP8M	144	BG1816UP8M	227		

· Made to order Lot sales items, Please inquire about us for the number of lots.

### ■ Pulley Dimensions (Reference)

No. of teeth	Pitch circle dia	Flange OD	No. of teeth	Pitch circle dia	Flange OD	No. of teeth	Pitch circle dia	Flange OD
<b>20</b>	50.93	55	<b>32</b>	81.49	86	<b>50</b>	127.32	135
<b>22</b>	56.02	62	<b>34</b>	86.58	91	<b>60</b>	152.79	158
<b>24</b>	61.12	66	<b>36</b>	91.67	97	<b>64</b>	162.97	170
<b>26</b>	66.21	73	<b>40</b>	101.86	107	<b>72</b>	183.35	190
<b>28</b>	71.30	79	<b>44</b>	112.05	119			
<b>30</b>	76.39	82	<b>48</b>	122.23	127			



## UP14M-HY (P : 14 mm)

### ■ Belt Tooth Profile and Dimensions

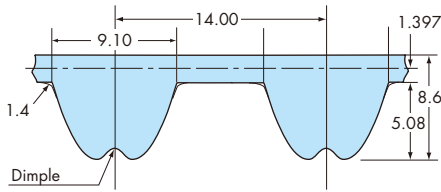

### ■ Model Identification

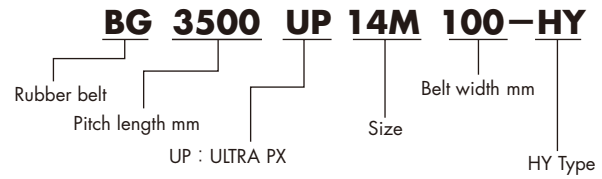

### ■ Materials

Rubber : High Intensity Synthetic rubber (Gray)  
 Fabric : Wear-resistant Fabric  
 Cord : Hybrid of carbon fiber and high intensity fiberglass

### ■ Specifications and Characteristic

Pulley : Unusable PX Pulley P14M  
 Usable special pulley  
 Temperature Range : -15°C ~ +80°C Oil proof, Water proof : No ( Unusable )  
 Conductive property : No RoHS Directive : Compliance

### ■ Belt Width / Width Factor / Unit Mass / Installation Tension

Belt width mm	Belt width factor	Weight kg/m	Installation Tension N {kgf}	
			Recommended	Max. Value
40	1.00	0.324	1020	1225
60	1.58	0.486	1580	1900
80	2.18	0.648	2140	2570
100	2.80	0.810	2700	3240
120	3.43	0.972	3260	3915

Please inquire about us for transmission capacity and selection.

### ■ Belt Length

Belt length	No. of teeth	Belt length	No. of teeth
BG1120UP14M	80	BG3500UP14M	250
BG1190UP14M	85	BG3850UP14M	275
BG1246UP14M	89	BG4004UP14M	286
BG1344UP14M	96	BG4508UP14M	322
BG1400UP14M	100		
BG1540UP14M	110		
BG1610UP14M	115		
BG1652UP14M	118		
BG1680UP14M	120		
BG1736UP14M	124		
BG1778UP14M	127		
BG1806UP14M	129		
BG1890UP14M	135		
BG1960UP14M	140		
BG2002UP14M	143		
BG2100UP14M	150		
BG2240UP14M	160		
BG2310UP14M	165		
BG2380UP14M	170		
BG2450UP14M	175		
BG2590UP14M	185		
BG2660UP14M	190		
BG2800UP14M	200		
BG3150UP14M	225		
BG3360UP14M	240		

· Made to order Lot sales items, Please inquire about us for the number of lots.

### ■ Pulley Dimensions (Reference)

No. of teeth	Pitch circle dia	Flange OD	No. of teeth	Pitch circle dia	Flange OD	No. of teeth	Pitch circle dia	Flange OD
28	124.78	136	38	169.34	181	50	222.82	234
30	133.69	145	40	178.25	190	56	249.55	-
32	142.60	154	42	187.17	198	60	267.38	-
34	151.52	163	44	196.08	207	64	285.21	-
36	160.43	171	48	213.90	225	72	320.86	-

mm

· Unusable PX Pulley P14M. Usable special pulley

Pulley Specifications (Reference) P55

## PX / ULTRA PX-HC

### ■ Belt Tooth Profile

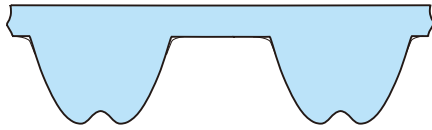

\* See pages 11 to 14 and 18 to 20 for the tooth shape, dimensions, material, specifications, and characteristics.

### ■ Model Identification

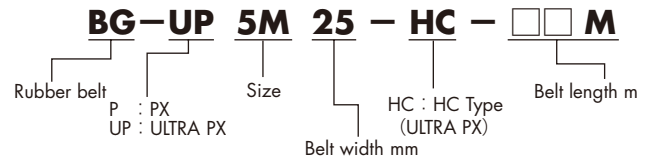

### ■ Manufacturable lengths (List types)

Series, Pitch Size		Belt width mm	4	6	10	15	20	25
PX Belt	<b>P2M</b>	105	70	45	-	-	-	-
	<b>P3M</b>	-	110	65	45	-	-	-
	<b>P5M</b>	-	-	130	85	65	50	-
	<b>P8M</b>	-	-	-	85	65	50	-
ULTRA PX Belt HC Type	<b>UP3M-HC</b>	-	110	65	45	-	-	-
	<b>UP5M-HC</b>	-	-	130	85	65	50	-
	<b>UP8M-HC</b>	-	-	-	85	65	50	-

- Transmission Capacity Tables P29~
- Pulley Specifications P51~
- Selection and Design P39

· Stock items

### ■ Application

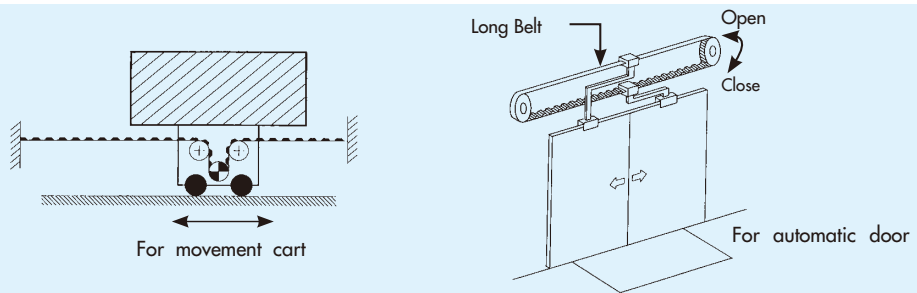

## Tsubaki Belt Clamp

The Tsubaki belt clamp is a metal fitting for fixing a work to the belt, fixing a long belt, etc. The belt clamps become the standard stock products to improve availability. Place orders for the Tsubaki belt clamps together with the Tsubaki timing belts and pulleys.

### Features

#### ■ Standard stock product

This product is kept in stock and shipped immediately. It is available as soon as you place an order.

#### ■ Holes have been made.

This product has fitting holes, and the customer can use it immediately after purchasing.

#### ■ Model No. example

**BDCP-P5M 10**

Belt clamp | Type (pitch) | Use belt width (mm)

#### ■ Material

P5M, P8M : High-strength aluminum (white anodized aluminum)



See the separate catalog for details.

### ■ Type & dimension list

Product code Model No.	Type, pitch	Applicable belt width (mm)	Width A	Length B	Overall thickness H	Tooth height T	Fitting hole pitch a	Fitting hole pitch b	Fitting hole diameter d	Tooth shape pitch P	
BDCP-P5M10	P5M	10	27	32	6	1.90	16	21	25	4.5	5.00
BDCP-P5M15		15	32	37			21				
BDCP-P5M20		20	37	42			26				
BDCP-P5M25		25	42	31			31				
BDCP-P8M15	P8M	15	34	54	8	3.00	22	40	5.5	8.00	
BDCP-P8M20		20	39	27							
BDCP-P8M25		25	44	32							

### ■ Shape

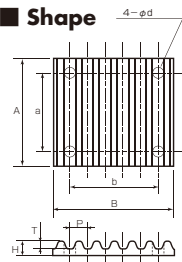

### Use examples

Example 1: Fixing works that move reciprocally

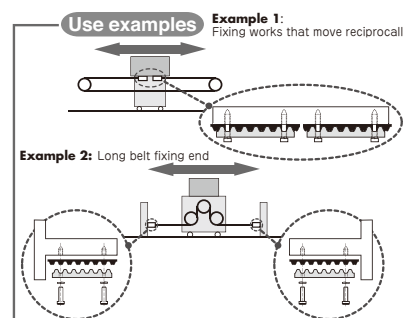











## P8M

### Standard Transmission Capacity (Belt width 15 mm)

		kW																	
Number of teeth of small pulley		20	22	24	26	28	30	32	34	36	38	40	44	48	50	56	60	64	72
Pitch circle diameter mm		50.93	56.02	61.12	66.21	71.30	76.39	81.49	86.58	91.67	96.77	101.86	112.05	122.23	127.32	142.60	152.79	162.97	183.35
Small pulley revolution /min	20	0.04	0.04	0.04	0.04	0.04	0.04	0.05	0.05	0.05	0.06	0.06	0.07	0.08	0.09	0.10	0.12	0.13	0.17
	40	0.07	0.07	0.08	0.08	0.08	0.09	0.09	0.10	0.11	0.11	0.12	0.14	0.16	0.17	0.21	0.24	0.27	0.33
	60	0.11	0.11	0.12	0.12	0.13	0.13	0.14	0.15	0.16	0.17	0.18	0.21	0.24	0.26	0.31	0.35	0.40	0.50
	100	0.18	0.19	0.19	0.20	0.21	0.22	0.24	0.25	0.27	0.29	0.31	0.35	0.40	0.43	0.52	0.58	0.66	0.82
	200	0.36	0.37	0.39	0.41	0.43	0.45	0.48	0.50	0.54	0.57	0.61	0.70	0.79	0.84	1.02	1.15	1.30	1.62
	300	0.55	0.56	0.58	0.61	0.64	0.67	0.71	0.76	0.80	0.86	0.91	1.04	1.18	1.26	1.51	1.71	1.92	2.39
	400	0.73	0.75	0.78	0.82	0.86	0.90	0.95	1.01	1.07	1.14	1.21	1.37	1.56	1.66	2.00	2.25	2.52	3.14
	500	0.91	0.94	0.98	1.02	1.07	1.13	1.19	1.26	1.33	1.42	1.51	1.71	1.93	2.06	2.47	2.78	3.11	3.86
	600	1.10	1.13	1.18	1.23	1.28	1.35	1.42	1.51	1.60	1.69	1.80	2.03	2.30	2.44	2.93	3.29	3.68	4.56
	700	1.28	1.32	1.37	1.43	1.50	1.58	1.66	1.75	1.86	1.97	2.09	2.36	2.66	2.83	3.37	3.78	4.23	5.23
	800	1.47	1.51	1.57	1.64	1.71	1.80	1.89	2.00	2.12	2.24	2.38	2.67	3.01	3.20	3.81	4.27	4.76	5.87
	900	1.65	1.70	1.77	1.84	1.93	2.02	2.13	2.24	2.37	2.51	2.66	2.99	3.36	3.56	4.23	4.73	5.28	6.49
	1 000	1.83	1.89	1.96	2.04	2.14	2.24	2.36	2.48	2.62	2.77	2.94	3.29	3.70	3.92	4.64	5.18	5.77	7.08
	1 100	2.01	2.08	2.15	2.24	2.35	2.46	2.59	2.72	2.87	3.04	3.21	3.60	4.03	4.27	5.04	5.62	6.25	7.65
	1 200	2.19	2.26	2.34	2.44	2.55	2.68	2.81	2.96	3.12	3.29	3.48	3.89	4.35	4.60	5.43	6.04	6.71	8.19
	1 300	2.36	2.44	2.53	2.64	2.76	2.89	3.03	3.19	3.36	3.55	3.75	4.18	4.67	4.93	5.81	6.45	7.15	8.71
	1 400	2.53	2.62	2.72	2.83	2.96	3.10	3.26	3.42	3.60	3.80	4.01	4.47	4.98	5.26	6.17	6.84	7.57	9.20
	1 450	2.62	2.71	2.81	2.93	3.06	3.21	3.36	3.54	3.72	3.92	4.14	4.61	5.13	5.41	6.34	7.03	7.78	9.44
	1 500	2.70	2.80	2.90	3.02	3.16	3.31	3.47	3.65	3.84	4.05	4.26	4.74	5.28	5.57	6.52	7.22	7.98	9.66
	1 600	2.87	2.97	3.08	3.21	3.35	3.51	3.69	3.87	4.07	4.29	4.52	5.02	5.57	5.87	6.86	7.58	8.37	10.10
	1 750	3.11	3.22	3.35	3.49	3.64	3.81	4.00	4.20	4.41	4.64	4.88	5.41	6.00	6.31	7.34	8.10	8.91	10.72
	1 800	3.18	3.30	3.43	3.58	3.74	3.91	4.10	4.30	4.52	4.76	5.00	5.54	6.13	6.45	7.49	8.26	9.09	10.91
	2 000	3.48	3.61	3.76	3.92	4.10	4.29	4.50	4.72	4.95	5.20	5.47	6.03	6.66	6.99	8.08	8.88	9.73	11.61
	2 400	4.00	4.17	4.36	4.56	4.79	5.00	5.24	5.49	5.75	6.03	6.32	6.94	7.61	7.96	9.10	9.93	10.80	12.71
2 800	4.40	4.62	4.85	5.09	5.34	5.61	5.88	6.16	6.45	6.75	7.06	7.71	8.40	8.77	9.91	10.72	11.58	13.40	
3 000	4.55	4.80	5.05	5.32	5.59	5.87	6.15	6.45	6.75	7.07	7.38	8.05	8.74	9.10	10.23	11.03	11.85	13.60	
3 600		5.10	5.44	5.78	6.12	6.46	6.80	7.14	7.48	7.82	8.16	8.84	9.52	9.86	10.87	11.55	12.23	13.58	
4 000			5.49	5.89	6.29	6.67	7.05	7.42	7.79	8.14	8.49	9.17	9.81	10.13	11.02	11.57	12.10	13.06	
5 000				5.32	5.88	6.42	6.92	7.38	7.82	8.22	8.59	9.23	9.73	9.94	10.35				
6 000				3.27	4.07	4.81	5.48	6.08	6.61	7.07	7.47	8.05	8.36	8.41					

### Standard Transmission Torque (Belt width 15 mm)

		N·m																	
Number of teeth of small pulley		20	22	24	26	28	30	32	34	36	38	40	44	48	50	56	60	64	72
Pitch circle diameter mm		50.93	56.02	61.12	66.21	71.30	76.39	81.49	86.58	91.67	96.77	101.86	112.05	122.23	127.32	142.60	152.79	162.97	183.35
Small pulley revolution /min	20	19.09	19.09	19.09	19.09	19.09	19.09	19.09	23.86	23.86	23.86	28.64	33.41	38.18	42.95	47.73	57.27	62.04	81.13
	40	16.70	16.70	19.09	19.09	19.09	21.48	21.48	23.86	26.25	26.25	28.64	33.41	38.18	40.57	50.11	57.27	64.43	78.75
	60	17.50	17.50	19.09	19.09	20.68	20.68	22.27	23.86	25.45	27.04	28.64	33.41	38.18	41.36	49.32	55.68	63.63	79.54
	100	17.18	18.14	18.14	19.09	20.64	20.64	22.91	23.86	25.77	27.68	29.59	33.41	38.18	41.04	49.32	55.36	63.00	78.27
	200	17.18	17.66	18.61	19.57	20.52	21.48	22.91	23.86	25.77	27.20	29.11	33.41	37.70	40.09	48.68	54.88	62.04	77.32
	300	17.50	17.82	18.45	19.41	20.36	21.32	22.59	24.18	25.45	27.36	28.95	33.09	37.54	40.09	48.04	54.41	61.09	76.04
	400	17.42	17.90	18.61	19.57	20.52	21.48	22.67	24.10	25.53	27.20	28.87	32.69	37.23	39.61	47.73	53.69	60.13	74.93
	500	17.37	17.94	18.71	19.47	20.43	21.57	22.72	24.05	25.39	27.11	28.83	32.64	36.84	39.33	47.15	53.07	59.37	73.69
	600	17.50	17.98	18.77	19.57	20.36	21.48	22.59	24.02	25.45	26.89	28.64	32.29	36.59	38.82	46.61	52.34	58.54	72.54
	700	17.45	18.00	18.68	19.50	20.45	21.54	22.64	23.86	25.36	26.86	28.50	32.18	36.27	38.59	45.95	51.54	57.68	71.32
	800	17.54	18.02	18.73	19.57	20.40	21.48	22.55	23.86	25.29	26.73	28.40	31.86	35.91	38.18	45.46	50.95	56.79	70.04
	900	17.50	18.03	18.77	19.51	20.47	21.42	22.59	23.76	25.14	26.62	28.21	31.71	35.64	37.76	44.86	50.17	56.00	68.83
	1 000	17.47	18.04	18.71	19.47	20.43	21.38	22.53	23.67	25.01	26.44	28.06	31.40	35.32	37.42	44.29	49.44	55.08	67.58
	1 100	17.44	18.05	18.66	19.44	20.39	21.35	22.47	23.60	24.90	26.38	27.85	31.24	34.97	37.05	43.73	48.77	54.23	66.38
	1 200	17.42	17.98	18.61	19.41	20.28	21.32	22.35	23.54	24.82	26.17	27.68	30.94	34.60	36.59	43.19	48.04	53.37	65.15
	1 300	17.33	17.92	18.58	19.38	20.27	21.22	22.25	23.42	24.67	26.07	27.53	30.69	34.29	36.20	42.66	47.36	52.50	63.95
	1 400	17.25	17.86	18.54	19.29	20.20	21.14	22.23	23.32	24.54	25.91	27.34	30.48	33.95	35.86	42.07	46.64	51.61	62.73
	1 450	17.25	17.84	18.50	19.29	20.14	21.13	22.12	23.30	24.49	25.80	27.25	30.35	33.77	35.61	41.74	46.28	51.21	62.14
	1 500	17.18	17.82	18.45	19.22	21.38	21.06	22.08	23.23	24.44	25.77	27.11	30.16	33.60	35.44	41.49	45.94	50.78	61.47
	1 600	17.12	17.72	18.37	19.15	21.42	20.94	22.01	23.09	24.28	25.59	26.97	29.95	33.23	35.02	40.93	45.22	49.93	60.25
	1 750	16.96	17.56	18.27	19.04	19.87	20.78	21.82	22.91	24.05	25.31	26.62	29.51	32.73	34.42	40.04	44.18	48.60	58.47
	1 800	16.86	17.50	18.19	18.98	19.82	20.73	21.74	22.80	23.97	25.24	26.51	29.38	32.51	34.20	39.72	43.80	48.20	57.85
	2 000	16.61	17.23	17.94	18.71	19.58	20.47	21.48	22.53	23.62	24.82	26.11	28.78	31.79	33.36	38.56	42.38	46.44	55.41
	2 400	15.91	16.58	17.34	18.14	18.98	19.89	20.84	21.83	22.87	23.98	25.14	27.60	30.27	31.66	36.19	39.49	42.95	50.55
2 800	15.00	15.75	16.53	17.35	18.20	19.12	20.04	21.00	21.99	23.01	24.07	26.28	28.64	29.90	33.78	36.54	39.48	45.68	
3 000	14.48	15.27	16.07	16.93	17.79	18.68	19.57	20.52	21.48	22.49	23.48	25.61	27.81	28.95	32.55	35.09	37.70	43.27	
3 600		13.52	14.42	15.33	16.23	17.13	18.03	18.93	19.83	20.73	21.64	23.44	25.24	26.14	28.82	30.62	32.43	36.01	
4 000			13.10	14.06	15.01	15.92	16.82	17.71	18.59	19.42	20.26	21.88	23.41	24.17	26.30	27.61	28.87	31.17	
5 000				10.16	11.23	12.26	13.21	14.09	14.93	15.69	16.40	17.62	18.57	18.98	19.76				
6 000				5.20	6.47	7.65	8.72	9.67	10.52	11.25	11.88	12.81	13.30	13.38					

### Width Factor



## P14M

### Standard Transmission Capacity (Belt width 40 mm)

Number of teeth of small pulley		kW															
Pitch circle diameter mm		28	30	32	34	36	38	40	42	44	46	48	50	56	60	64	72
Small pulley revolution r/min	20	0.3	0.4	0.5	0.6	0.6	0.7	0.8	0.8	0.9	0.9	1.0	1.0	1.1	1.2	1.3	1.4
	40	0.7	0.8	1.0	1.1	1.3	1.4	1.5	1.6	1.7	1.8	1.9	2.0	2.3	2.4	2.6	2.8
	60	1.0	1.3	1.5	1.7	1.9	2.1	2.2	2.4	2.6	2.7	2.9	3.0	3.4	3.6	3.8	4.2
	100	1.7	2.1	2.5	2.8	3.1	3.4	3.7	4.0	4.2	4.5	4.7	4.9	5.5	5.9	6.2	6.8
	200	3.4	4.2	4.9	5.5	6.1	6.7	7.2	7.7	8.2	8.7	9.1	9.5	10.6	11.3	11.9	13.0
	400	6.7	8.1	9.5	10.7	11.8	12.8	13.8	14.7	15.5	16.3	17.0	17.7	19.6	20.6	21.6	23.4
	500	8.2	10.0	11.6	13.1	14.4	15.7	16.8	17.9	18.8	19.7	20.6	21.3	23.4	24.7	25.8	27.8
	600	9.8	11.9	13.8	15.5	17.0	18.4	19.7	20.9	22.0	22.9	23.9	24.8	27.0	28.3	29.5	31.6
	800	12.9	15.5	17.9	20.0	21.9	23.5	25.0	26.4	27.7	28.8	29.8	30.8	33.2	34.6	35.8	38.0
	1 000	15.8	19.0	21.7	24.2	26.3	28.2	29.8	31.3	32.6	33.8	34.9	35.9	38.3	39.6	40.8	42.8
	1 200	18.7	22.3	25.4	28.1	30.4	32.4	34.1	35.6	37.0	38.1	39.2	40.1	42.4	43.5	44.5	46.2
	1 400	21.5	25.4	28.8	31.7	34.1	36.2	37.9	39.4	40.8	41.8	42.8	43.7	45.6	46.5	47.3	48.6
	1 450	22.1	26.2	29.6	32.5	35.0	37.1	38.8	40.3	41.6	42.7	43.6	44.4	46.2	47.1	47.8	49.0
	1 500	22.8	27.0	30.5	33.4	35.9	37.9	39.7	41.1	42.4	43.5	44.4	45.2	46.9	47.7	48.3	49.4
	1 600	24.1	28.4	32.0	35.0	37.5	39.6	41.3	42.7	44.0	44.9	45.8	46.5	48.0	48.7	49.2	50.0
	1 750	26.1	30.6	34.3	37.4	39.9	41.9	43.6	44.9	46.1	46.9	47.7	48.3	49.4	49.8	50.1	50.6
	1 800	26.7	31.3	35.0	38.1	40.6	42.6	44.3	45.6	46.7	47.5	48.2	48.8	49.7	50.1	50.3	50.7
	2 000	29.2	34.0	37.9	41.0	43.5	45.4	46.9	48.1	49.0	49.7	50.2	50.6	51.0	51.0	50.9	50.8
	2 400	33.9	39.1	43.0	46.1	48.3	50.0	51.2	51.9	52.5	52.7	52.8	52.7	52.0	51.4	50.7	49.4
	3 000	40.4	45.7	49.5	52.2	53.9	54.9	55.4	55.4	55.2	54.7	54.2	53.4	51.0			
3 600	46.1	51.3	54.7	56.7	57.6	57.8		56.8	55.8								
4 000	49.6	54.6	57.6	58.8	59.4	59.0	58.1										

### Standard Transmission Torque (Belt width 40 mm)

Number of teeth of small pulley		N · m															
Pitch circle diameter mm		28	30	32	34	36	38	40	42	44	46	48	50	56	60	64	72
Small pulley revolution r/min	20	162	200	239	272	301	334	358	387	410	434	458	482	544	582	616	682
	40	165	200	236	270	301	332	358	384	410	434	458	480	539	577	611	673
	60	164	200	235	269	301	329	356	382	407	431	453	476	536	571	606	667
	100	162	200	235	267	298	326	353	379	403	426	449	470	527	562	595	653
	200	161	198	231	263	292	319	345	369	392	413	434	453	506	537	567	619
	400	159	194	226	255	281	306	329	350	370	388	406	422	467	492	516	558
	500	157	191	222	250	276	299	321	341	359	376	392	407	447	471	492	530
	600	156	189	219	246	271	293	313	332	349	365	380	394	430	451	470	503
	800	154	185	213	238	261	281	299	315	330	343	356	367	396	413	428	453
	1 000	151	181	208	231	251	269	285	299	312	323	333	342	365	378	389	408
	1 200	149	177	202	223	242	257	271	283	294	303	312	319	337	346	354	368
	1 400	146	173	196	216	232	247	259	269	278	285	292	298	311	317	322	331
	1 450	146	173	195	214	230	244	256	265	274	281	287	292	304	310	315	323
	1 500	145	172	194	212	228	241	253	262	270	276	283	287	298	303	308	314
	1 600	144	170	191	209	224	236	247	255	262	268	273	278	286	290	293	298
	1 750	142	167	187	204	218	229	238	245	251	256	260	263	270	272	273	276
	1 800	141	166	186	202	215	226	235	242	248	252	256	259	264	266	267	269
	2 000	139	162	181	196	207	217	224	229	234	237	240	241	243	243	243	242
	2 400	135	155	171	183	192	199	204	206	209	209	210	210	207	204	201	197
	3 000	128	145	158	166	171	175	176	176	174	172		170	162			
3 600	122	136	145	150	153	153	152	150	148								
4 000	118	130	137	140	142	141	139										

### Width Factor

Belt width mm	40	60	80	100	120
Width Factor	1.00	1.59	2.20	2.84	3.50

Belt Types and Dimensions P15

Selection and Design P39

· notes;

The **xxx** area makes the belt life shorter and should be avoided.

The pulley speed increases to 33 m/s or over in the **xxx** area and therefore the pulleys must be kept in good balance.



## UP3M-HC

### Standard Transmission Capacity (Belt width 6 mm)

Number of teeth of small pulley		W																			
Pitch circle diameter mm		12	14	15	16	18	20	22	24	25	26	28	30	32	36	40	48	50	60		
Small pulley diameter mm	20	2	2	3	3	4	4	5	6	6	6	7	7	8	9	10	12	13	15		
	40	3	4	5	6	7	8	9	10	11	11	13	14	15	17	19	23	24	29		
	60	5	6	7	8	10	11	13	15	16	16	18	20	21	24	27	33	34	41		
	100	7	10	11	13	15	18	21	23	24	26	28	31	33	38	43	51	54	64		
	200	14	18	21	24	29	33	38	43	45	47	52	56	61	70	78	94	98	118		
	Small pulley revolution r/min	400	25	34	38	43	52	60	69	77	82	86	94	103	111	127	142	172	179	215	
		600	35	48	54	61	73	85	98	109	116	121	133	145	156	179	201	243	253	304	
		800	44	60	69	77	93	109	125	140	147	155	170	185	199	229	256	310	323	388	
		1 000	53	73	83	93	112	131	150	168	178	187	205	223	241	275	309	373	388	467	
		1 200	63	86	98	109	132	155	177	198	210	220	241	262	283	324	363	439	457	549	
		Small pulley revolution r/min	1 400	71	99	113	125	151	176	203	227	240	252	277	301	325	371	417	504	524	631
			1 450	74	103	116	130	157	183	210	234	247	260	286	312	336	384	430	520	541	650
			1 500	77	105	120	133	162	188	217	242	255	268	295	321	345	395	443	536	558	671
			1 600	80	111	127	141	172	200	229	256	272	284	313	340	366	420	470	568	591	711
			1 750	89	120	138	154	185	217	248	278	294	309	339	369	396	455	510	615	643	771
			1 800	92	124	140	157	191	222	256	285	301	317	348	378	407	466	522	632	659	791
			2 000	105	137	155	174	210	244	281	315	331	349	381	416	448	514	576	694	724	870
			2 400	121	160	183	202	246	285	329	368	387	407	445	487	523	600	672	810	846	1 015
			3 000	151	202	222	246	299	348	398	447	472	496	542	591	637	729	817	986	1 024	1 229
			3 600	181	256	282	315	382	444	506	568	602	631	693	755	812	927	1 037	1 252	1 299	1 557
Small pulley diameter mm		4 000	211	337	375	420	507	580	653	715	753	825	898	970	1 108	1 235	1 488	1 548	1 843		
		5 000	261	417	464	520	617	700	773	835	873	945	1 018	1 156	1 283	1 536	1 692	1 764	2 089		
		6 000	311	497	554	610	717	800	873	935	973	1 045	1 118	1 256	1 404	1 656	1 812	1 904	2 296		
		8 000	401	647	714	780	917	1 000	1 073	1 135	1 173	1 245	1 318	1 456	1 604	1 856	2 112	2 204	2 696		
		10 000	501	807	884	960	1 127	1 220	1 293	1 355	1 393	1 465	1 538	1 676	1 824	2 076	2 332	2 424	2 996		
	12 000	601	967	1 054	1 130	1 317	1 420	1 493	1 555	1 593	1 665	1 738	1 876	2 024	2 276	2 532	2 624	3 296			
	14 000	701	1 127	1 224	1 300	1 507	1 620	1 693	1 755	1 793	1 865	1 938	2 076	2 224	2 476	2 732	2 824	3 596			

### Standard Transmission Torque (Belt width 6 mm)

Number of teeth of small pulley		N • m																		
Pitch circle diameter mm		12	14	15	16	18	20	22	24	25	26	28	30	32	36	40	48	50	60	
Small pulley diameter mm	20	0.83	1.14	1.30	1.45	1.76	2.05	2.35	2.63	2.78	2.92	3.20	3.48	3.76	4.30	4.82	5.82	6.08	7.30	
	40	0.77	1.07	1.21	1.35	1.64	1.91	2.19	2.45	2.59	2.72	2.99	3.25	3.50	4.00	4.49	5.44	5.66	6.81	
	60	0.74	1.02	1.16	1.29	1.57	1.82	2.10	2.34	2.48	2.61	2.86	3.11	3.35	3.84	4.31	5.20	5.42	6.51	
	100	0.70	0.96	1.09	1.22	1.48	1.72	1.98	2.21	2.34	2.46	2.69	2.94	3.16	3.62	4.06	4.91	5.11	6.15	
	200	0.64	0.88	1.00	1.13	1.36	1.59	1.82	2.04	2.15	2.26	2.48	2.69	2.91	3.32	3.72	4.50	4.70	5.65	
	Small pulley revolution r/min	400	0.58	0.80	0.91	1.02	1.24	1.44	1.65	1.85	1.96	2.05	2.25	2.45	2.64	3.03	3.40	4.09	4.27	5.14
		600	0.56	0.76	0.86	0.97	1.16	1.36	1.56	1.74	1.84	1.93	2.12	2.31	2.49	2.85	3.20	3.86	4.03	4.84
		800	0.52	0.72	0.82	0.92	1.11	1.30	1.49	1.67	1.76	1.85	2.03	2.21	2.38	2.73	3.06	3.69	3.85	4.63
		1 000	0.50	0.70	0.79	0.89	1.07	1.25	1.43	1.61	1.70	1.78	1.96	2.13	2.30	2.63	2.95	3.56	3.71	4.46
		1 200	0.50	0.69	0.78	0.86	1.05	1.23	1.41	1.57	1.67	1.75	1.92	2.08	2.25	2.57	2.89	3.49	3.64	4.37
		1 400	0.48	0.67	0.77	0.85	1.03	1.20	1.38	1.55	1.63	1.72	1.89	2.06	2.21	2.53	2.85	3.44	3.57	4.30
		1 450	0.49	0.68	0.76	0.86	1.04	1.20	1.38	1.54	1.63	1.71	1.88	2.05	2.21	2.53	2.83	3.42	3.56	4.28
		1 500	0.49	0.67	0.76	0.85	1.03	1.20	1.38	1.54	1.62	1.71	1.88	2.05	2.19	2.51	2.82	3.41	3.55	4.27
		1 600	0.48	0.66	0.76	0.84	1.02	1.19	1.36	1.52	1.62	1.69	1.87	2.03	2.19	2.51	2.80	3.39	3.53	4.24
		1 750	0.48	0.66	0.75	0.84	1.01	1.18	1.35	1.52	1.60	1.69	1.85	2.01	2.16	2.48	2.78	3.35	3.50	4.20
	Small pulley diameter mm	1 800	0.48	0.66	0.74	0.83	1.01	1.18	1.36	1.51	1.60	1.68	1.84	2.01	2.16	2.47	2.77	3.35	3.49	4.19
		2 000	0.48	0.65	0.74	0.83	1.00	1.17	1.34	1.50	1.58	1.67	1.82	1.98	2.14	2.45	2.75	3.31	3.46	4.15
		2 400	0.48	0.64	0.73	0.80	0.98	1.13	1.31	1.46	1.54	1.62	1.77	1.94	2.08	2.39	2.67	3.22	3.37	4.04
		3 000	0.48	0.68	0.78	0.86	1.04	1.20	1.36	1.52	1.60	1.68	1.84	2.00	2.16	2.47	2.77	3.35	3.49	4.19
		3 600	0.48	0.68	0.78	0.86	1.04	1.20	1.36	1.52	1.60	1.68	1.84	2.00	2.16	2.47	2.77	3.35	3.49	4.19
4 000		0.48	0.68	0.78	0.86	1.04	1.20	1.36	1.52	1.60	1.68	1.84	2.00	2.16	2.47	2.77	3.35	3.49	4.19	
5 000		0.48	0.68	0.78	0.86	1.04	1.20	1.36	1.52	1.60	1.68	1.84	2.00	2.16	2.47	2.77	3.35	3.49	4.19	
6 000		0.48	0.68	0.78	0.86	1.04	1.20	1.36	1.52	1.60	1.68	1.84	2.00	2.16	2.47	2.77	3.35	3.49	4.19	

### Width Factor

Belt width mm	6	10	15
Width Factor	1.00	1.78	2.84

Belt Types and Dimensions P18

Selection and Design P39

notes:

The **xxx** area makes the belt life shorter and should be avoided.



## UP5M-HC

### Standard Transmission Capacity (Belt width 10 mm)

W

Number of teeth of small pulley		12	14	16	18	20	22	24	26	28	30	32	36	40	44	48	50	60	72
Pitch circle diameter mm		19.10	22.28	25.46	28.65	31.83	35.01	38.20	41.38	44.56	47.75	50.93	57.30	63.66	70.03	76.39	79.58	95.49	114.59
Small pulley revolution r/min	20	10	12	15	17	19	21	24	26	29	31	34	39	45	51	58	61	78	101
	40	19	23	28	32	36	40	45	49	54	59	64	74	85	96	108	114	147	187
	60	27	32	39	45	50	56	63	69	76	83	90	104	119	135	152	161	206	267
	100	41	50	60	69	78	88	97	107	118	128	139	162	185	210	236	249	321	420
	200	76	92	111	128	145	162	180	198	215	237	257	298	342	388	436	460	592	774
	400	141	170	206	236	267	299	332	366	401	437	474	550	631	715	804	849	1 092	1 430
	500	172	207	251	287	325	364	405	446	488	532	577	670	769	871	979	1 034	1 330	1 741
	600	202	243	295	338	382	428	475	524	574	625	678	788	903	1 024	1 151	1 216	1 563	2 045
	800	260	314	380	436	492	552	613	675	740	806	875	1 016	1 164	1 320	1 483	1 567	2 016	2 637
	1 000	316	382	463	531	600	672	747	822	901	982	1 065	1 238	1 418	1 609	1 806	1 909	2 454	3 210
	1 200	376	453	550	630	713	799	887	977	1 070	1 167	1 265	1 470	1 685	1 910	2 146	2 266	2 913	3 811
	1 400	436	526	637	730	826	924	1 026	1 132	1 240	1 351	1 466	1 702	1 951	2 212	2 484	2 625	3 372	4 409
	1 450		544	658	755	854	957	1 061	1 171	1 283	1 397	1 516	1 760	2 017	2 288	2 569	2 714	3 488	4 559
1 500		561	681	780	883	988	1 098	1 209	1 324	1 444	1 566	1 819	2 084	2 364	2 654	2 803	3 601	4 707	
1 600		599	724	831	940	1 052	1 169	1 287	1 410	1 537	1 667	1 935	2 218	2 514	2 823	2 984	3 833	5 007	
1 750		652	790	907	1 025	1 147	1 275	1 405	1 539	1 677	1 817	2 111	2 420	2 743	3 080	3 254	4 178	5 455	
1 800			813	931	1 053	1 179	1 309	1 443	1 582	1 724	1 868	2 171	2 486	2 820	3 165	3 344	4 293	5 605	
2 000			902	1 032	1 169	1 309	1 453	1 601	1 754	1 912	2 071	2 407	2 757	3 124	3 508	3 707	4 687	6 201	
2 400			1 068	1 222	1 386	1 552	1 720	1 897	2 077	2 262	2 453	2 849	3 261	3 695	4 146	4 378	5 485	7 293	
3 000				1 517	1 714	1 918	2 130	2 348	2 570	2 798	3 034	3 520	4 027	4 559	5 108	5 389	6 614	8 885	
3 600				1 794	2 029	2 272	2 519	2 774	3 039	3 307	3 584	4 151	4 743	5 361	5 996	6 320	7 629	10 250	
4 000					2 245	2 513	2 785	3 067	3 358	3 655	3 956	4 577	5 226	5 895	6 583	6 932	8 040	11 069	
5 000					2 747	3 072	3 404	3 747	4 090	4 446	4 807	5 542	6 301	7 066	7 843	8 229	9 048		
6 000					3 217	3 585	3 969	4 359	4 757	5 154	5 559	6 376	7 185	7 995	8 776	9 159			
8 000						5 002	5 455	5 908	6 361	6 795	7 224	8 366	8 993	9 465					
10 000							6 313	6 747	7 156	7 518	8 072		8 349	8 253					
12 000							6 824	7 142	7 359	7 475	7 316								
14 000							6 848	6 882	6 730										

### Standard Transmission Torque (Belt width 10 mm)

N · m

Number of teeth of small pulley		12	14	16	18	20	22	24	26	28	30	32	36	40	44	48	50	60	72
Pitch circle diameter mm		19.10	22.28	25.46	28.65	31.83	35.01	38.20	41.38	44.56	47.75	50.93	57.30	63.66	70.03	76.39	79.58	95.49	114.59
Small pulley revolution r/min	20	4.81	5.80	7.04	8.06	9.13	10.22	11.36	12.51	13.71	14.94	16.20	18.82	21.58	24.46	27.48	29.04	37.34	48.25
	40	4.53	5.47	6.62	7.59	8.59	9.61	10.68	11.77	12.89	14.05	15.23	17.70	20.29	23.01	25.85	27.31	35.11	44.53
	60	4.23	5.11	6.19	7.09	8.03	8.99	9.98	11.00	12.05	13.14	14.25	16.55	18.97	21.52	24.17	25.54	32.84	42.49
	100	3.95	4.76	5.76	6.61	7.48	8.37	9.30	10.25	11.23	12.24	13.27	15.42	17.68	20.04	22.52	23.80	30.60	40.06
	200	3.64	4.39	5.32	6.10	6.91	7.73	8.58	9.46	10.26	11.29	12.26	14.23	16.32	18.51	20.79	21.96	28.24	36.96
	400	3.36	4.05	4.91	5.63	6.37	7.13	7.92	8.73	9.56	10.42	11.31	13.13	15.05	17.07	19.18	20.26	26.06	34.12
	500	3.28	3.95	4.79	5.48	6.21	6.95	7.72	8.51	9.33	10.16	11.02	12.80	14.68	16.64	18.69	19.75	25.40	33.24
	600	3.21	3.86	4.69	5.38	6.07	6.80	7.55	8.34	9.13	9.95	10.79	12.53	14.37	16.29	18.30	19.34	24.86	32.54
	800	3.10	3.75	4.54	5.20	5.88	6.59	7.32	8.06	8.83	9.62	10.43	12.12	13.89	15.75	17.70	18.70	24.05	31.47
	1 000	3.02	3.65	4.42	5.07	5.73	6.42	7.13	7.85	8.60	9.37	10.17	11.81	13.53	15.36	17.24	18.22	23.42	30.64
	1 200	2.99	3.61	4.38	5.01	5.67	6.36	7.05	7.77	8.51	9.28	10.07	11.69	13.40	15.19	17.07	18.03	23.17	30.31
	1 400	2.97	3.58	4.34	4.97	5.63	6.30	7.00	7.72	8.45	9.21	9.99	11.60	13.30	15.08	16.94	17.90	22.99	30.06
	1 450		3.58	4.33	4.97	5.62	6.30	6.99	7.71	8.45	9.20	9.98	11.58	13.28	15.06	16.91	17.86	22.96	30.01
1 500		3.57	4.34	4.96	5.62	6.29	6.99	7.70	8.43	9.19	9.96	11.58	13.26	15.04	16.89	17.84	22.92	29.96	
1 600		3.57	4.32	4.96	5.61	6.28	6.97	7.68	8.41	9.17	9.95	11.54	13.23	15.00	16.84	17.80	22.87	29.87	
1 750		3.56	4.31	4.95	5.59	6.26	6.96	7.66	8.40	9.15	9.91	11.51	13.20	14.96	16.80	17.75	22.79	29.76	
1 800			4.31	4.94	5.58	6.25	6.94	7.65	8.39	9.14	9.91	11.51	13.18	14.95	16.78	17.73	22.77	29.72	
2 000			4.31	4.93	5.58	6.25	6.93	7.64	8.37	9.12	9.89	11.49	13.16	14.91	16.74	17.69	22.37	29.59	
2 400			4.25	4.86	5.51	6.17	6.84	7.55	8.26	9.00	9.76	11.33	12.97	14.70	16.49	17.41	21.81	29.01	
3 000				4.83	5.45	6.10	6.78	7.47	8.18	8.90	9.65	11.20	12.81	14.50	16.25	17.15	21.04	28.27	
3 600				4.76	5.38	6.02	6.68	7.36	8.06	8.77	9.50	11.01	12.58	14.22	15.90	16.76	20.23	27.18	
4 000					5.36	6.00	6.65	7.32	8.01	8.72	9.44	10.92	12.47	14.07	15.71	16.54	19.19	26.41	
5 000					5.24	5.87	6.50	7.15	7.81	8.49	9.18	10.58	12.03	13.49	14.97	15.71			
6 000					5.12	5.70	6.31	6.93	7.57	8.20	8.84	10.14	11.43	12.72	13.96	14.57			
8 000						5.97	6.51	7.05	7.59	7.95	8.11	9.10	9.98	10.73	11.29	11.48			
10 000							6.03	6.44	6.83	7.18	7.71	7.97	7.88						
12 000							5.43	5.68	5.85	5.95	5.82								
14 000							4.67	4.69	4.59										

### Width Factor

Belt width mm	10	15	25
Width Factor	1.00	1.59	2.84

Belt Types and Dimensions P19

Selection and Design P39

notes:

The xxx area makes the belt life shorter and should be avoided.

## UP8M-HC

### Standard Transmission Capacity (Belt width 15 mm)

Number of teeth of small pulley	kW																	
	20	22	24	26	28	30	32	34	36	38	40	44	48	50	56	60	64	72
Pitch circle diameter mm	50.93	56.02	61.12	66.21	71.30	76.39	81.49	86.58	91.67	96.77	101.86	112.05	122.23	127.32	142.60	152.79	162.97	183.35
20	0.11	0.12	0.13	0.14	0.15	0.17	0.18	0.19	0.20	0.21	0.23	0.25	0.28	0.29	0.33	0.36	0.40	0.46
40	0.19	0.21	0.24	0.26	0.28	0.30	0.33	0.36	0.38	0.40	0.42	0.47	0.52	0.55	0.62	0.67	0.73	0.84
60	0.27	0.31	0.34	0.37	0.40	0.44	0.47	0.50	0.53	0.56	0.60	0.67	0.74	0.77	0.89	0.96	1.04	1.20
100	0.43	0.48	0.52	0.57	0.62	0.67	0.71	0.77	0.82	0.88	0.93	1.03	1.14	1.20	1.38	1.50	1.62	1.87
200	0.76	0.84	0.93	1.01	1.10	1.19	1.28	1.37	1.46	1.57	1.69	1.85	2.06	2.16	2.48	2.70	2.93	3.40
300	1.06	1.17	1.29	1.41	1.54	1.66	1.78	1.92	2.05	2.18	2.29	2.59	2.88	3.03	3.48	3.79	4.11	4.79
400	1.32	1.47	1.62	1.78	1.93	2.09	2.25	2.41	2.59	2.75	2.92	3.28	3.65	3.84	4.41	4.81	5.22	6.08
500	1.57	1.75	1.93	2.12	2.30	2.50	2.69	2.89	3.09	3.30	3.50	3.93	4.37	4.60	5.30	5.78	6.29	7.32
600	1.81	2.01	2.22	2.44	2.65	2.88	3.10	3.33	3.57	3.80	4.05	4.54	5.06	5.32	6.14	6.71	7.29	8.51
700	2.04	2.26	2.50	2.75	2.99	3.24	3.50	3.75	4.02	4.29	4.57	5.13	5.72	6.02	6.95	7.59	8.26	9.65
800	2.25	2.51	2.77	3.04	3.31	3.59	3.87	4.17	4.46	4.76	5.07	5.70	6.35	6.69	7.73	8.45	9.20	10.75
900	2.46	2.74	3.03	3.32	3.61	3.92	4.24	4.55	4.88	5.21	5.55	6.25	6.97	7.34	8.48	9.29	10.11	11.83
1 000	2.66	2.96	3.28	3.58	3.91	4.24	4.58	4.93	5.28	5.64	6.02	6.78	7.56	7.96	9.22	10.08	10.99	12.88
1 100	2.86	3.19	3.52	3.87	4.23	4.59	4.95	5.33	5.71	6.10	6.51	7.32	8.18	8.62	9.99	10.93	11.91	13.97
1 200	3.06	3.42	3.78	4.15	4.53	4.92	5.31	5.72	6.13	6.55	6.98	7.87	8.79	9.26	10.74	11.76	12.83	15.05
1 300	3.26	3.64	4.02	4.42	4.82	5.24	5.67	6.10	6.54	6.99	7.45	8.40	9.40	9.90	11.49	12.59	13.73	16.11
1 400	3.46	3.86	4.27	4.69	5.12	5.57	6.01	6.47	6.95	7.43	7.92	8.94	9.99	10.53	12.23	13.40	14.62	17.17
1 450	3.55	3.96	4.39	4.82	5.26	5.72	6.18	6.66	7.15	7.64	8.15	9.20	10.28	10.84	12.59	13.80	15.06	17.69
1 500	3.65	4.07	4.51	4.95	5.41	5.87	6.35	6.85	7.35	7.85	8.38	9.46	10.58	11.15	12.95	14.20	15.50	18.22
1 600	3.83	4.27	4.73	5.21	5.69	6.18	6.69	7.21	7.74	8.28	8.84	9.98	11.16	11.77	13.68	15.00	16.37	19.26
1 750	4.11	4.59	5.08	5.59	6.12	6.64	7.19	7.75	8.32	8.91	9.50	10.74	12.03	12.69	14.75	16.19	17.68	20.81
1 800	4.19	4.69	5.20	5.71	6.25	6.79	7.35	7.92	8.52	9.11	9.72	11.00	12.31	12.99	15.10	16.58	18.11	21.32
2 000	4.56	5.09	5.65	6.21	6.79	7.39	8.00	8.63	9.28	9.93	10.61	11.99	13.44	14.18	16.51	18.14	19.82	23.37
2 400	5.25	5.87	6.51	7.17	7.85	8.54	9.27	10.00	10.75	11.52	12.31	13.95	15.65	16.53	19.27	21.20	23.18	27.38
2 800	5.91	6.61	7.34	8.09	8.87	9.66	10.48	11.32	12.18	13.06	13.97	15.84	17.81	18.81	21.97	24.19	26.49	31.35
3 000	6.22	6.97	7.75	8.54	9.37	10.21	11.09	11.97	12.89	13.82	14.79	16.78	18.87	19.94	23.31	25.68	28.13	33.30
3 600	6.93	7.79	8.66	9.56	10.49	11.45	12.44	13.46	14.50	15.57	16.66	18.94	21.33	22.56	26.44	29.15	31.97	37.94
4 000	7.36	8.29	9.20	10.18	11.18	12.20	13.27	14.36	15.48	16.63	17.81	20.27	22.85	24.18	28.37	31.30	34.36	40.81
5 000	8.29	9.34	10.41	11.52	12.68	13.87	15.10	16.38	17.68	19.02	20.40	23.26	26.29	27.84	32.75	36.20		
6 000	9.05	9.05	11.41	12.65	13.95	15.28	16.66	18.08	19.55	21.06	22.61	25.85	29.24	31.02	36.56	40.46		

### Standard Transmission Torque (Belt width 15 mm)

Number of teeth of small pulley	N • m																	
	20	22	24	26	28	30	32	34	36	38	40	44	48	50	56	60	64	72
Pitch circle diameter mm	50.93	56.02	61.12	66.21	71.30	76.39	81.49	86.58	91.67	96.77	101.86	112.05	122.23	127.32	142.60	152.79	162.97	183.35
20	53.2	58.0	62.9	67.7	72.5	77.2	87.0	91.9	96.7	101.5	111.2	120.9	135.4	140.2	159.5	174.0	188.6	217.6
40	46.1	50.9	58.2	63.0	67.9	72.7	77.6	84.9	89.7	94.6	99.4	111.5	123.7	130.9	147.9	160.0	174.6	201.2
60	40.7	48.6	53.4	58.3	63.1	69.6	74.5	79.3	84.2	89.1	95.5	106.9	118.2	123.1	140.9	152.2	165.2	191.1
100	43.9	45.8	49.7	54.5	59.4	64.3	68.2	73.0	77.9	83.7	88.6	98.3	109.0	114.9	131.4	143.1	154.8	178.2
200	36.1	40.0	44.4	48.3	52.7	56.6	61.0	65.4	69.8	74.7	80.6	88.4	98.1	103.0	118.2	128.9	139.6	162.1
300	33.6	37.2	41.1	45.0	48.9	52.8	56.7	61.0	65.2	69.4	72.7	82.5	91.6	96.5	110.9	120.6	130.7	152.3
400	31.6	35.0	38.7	42.4	46.0	49.9	53.6	57.5	61.7	65.6	69.8	78.3	87.2	91.6	105.3	114.8	124.6	145.2
500	30.0	33.3	36.9	40.4	43.9	47.6	51.4	55.1	59.0	62.9	66.9	75.1	83.5	87.8	101.2	110.4	120.0	139.8
600	28.8	32.0	35.3	38.8	42.2	45.8	49.4	53.0	56.7	60.5	64.4	72.3	80.4	84.7	97.6	106.8	115.9	135.4
700	27.8	30.9	34.1	37.4	40.8	44.2	47.7	51.2	54.8	58.5	62.3	70.0	78.0	82.0	94.8	103.5	112.6	131.5
800	26.9	30.0	33.0	36.2	39.5	42.8	46.2	49.7	53.2	56.8	60.5	68.0	75.8	79.8	92.2	100.8	109.8	128.3
900	26.1	29.0	32.1	35.2	38.3	41.6	45.0	48.3	51.8	55.3	58.9	66.3	73.9	77.9	90.0	98.5	107.2	125.5
1 000	25.4	28.2	31.3	34.2	37.4	40.5	43.8	47.1	50.4	53.9	57.4	64.7	72.2	76.0	88.0	96.3	104.9	122.9
1 100	24.8	27.7	30.6	33.6	36.7	39.8	43.0	46.2	49.5	53.0	56.5	63.6	71.0	74.8	86.7	94.8	103.4	121.2
1 200	24.4	27.2	30.1	33.0	36.1	39.1	42.3	45.5	48.7	52.1	55.5	62.6	70.0	73.7	85.5	93.6	102.0	119.7
1 300	23.9	26.7	29.5	32.5	35.4	38.5	41.6	44.8	48.0	51.3	54.7	61.7	69.0	72.7	84.3	92.4	100.8	118.3
1 400	23.6	26.3	29.1	32.0	34.9	37.9	41.0	44.1	47.4	50.7	54.0	60.9	68.1	71.8	83.4	91.3	99.7	117.1
1 450	23.4	26.1	28.9	31.7	34.7	37.6	40.7	43.8	47.0	50.3	53.6	60.5	67.7	71.4	82.9	90.9	99.2	116.5
1 500	23.2	25.9	28.7	31.5	34.4	37.4	40.4	43.6	46.7	50.0	53.4	60.2	67.3	71.0	82.4	90.4	98.6	116.0
1 600	22.8	25.5	28.2	31.1	34.0	36.9	39.9	43.0	46.2	49.4	52.7	59.5	66.6	70.2	81.6	89.5	97.7	114.9
1 750	22.4	25.0	27.7	30.5	33.4	36.2	39.2	42.3	45.4	48.6	51.8	58.6	65.6	69.2	80.4	88.3	96.5	113.5
1 800	22.2	24.9	27.6	30.3	33.2	36.0	39.0	42.0	45.2	48.3	51.6	58.3	65.3	68.9	80.1	87.9	96.0	113.1
2 000	21.7	24.3	26.9	29.7	32.4	35.3	38.2	41.2	44.3	47.4	50.6	57.2	64.1	67.7	78.8	86.6	94.6	111.5
2 400	20.9	23.3	25.9	28.5	31.2	34.0	36.9	39.8	42.8	45.8	49.0	55.5	62.2	65.7	76.6	84.3	92.2	108.9
2 800	20.1	22.5	25.0	27.6	30.2	32.9	35.7	38.6	41.5	44.5	47.6	54.0	60.7	64.1	74.9	82.5	90.3	106.9
3 000	19.8	22.2	24.7	27.2	29.8	32.5	35.3	38.1	41.0	44.0	47.1	53.4	60.0	63.4	74.2	81.7	89.5	106.0
3 600	18.4	20.6	23.0	25.3	27.8	30.4	33.0	35.7	38.4	41.3	44.2	50.2	56.6	59.8	70.1	77.3	84.8	100.6
4 000	17.6	19.8	22.0	24.3	26.7	29.1	31.7	34.3	36.9	39.7	42.5	48.4	54.5	57.7	67.7	74.7	82.0	97.4
5 000	15.8	17.8	19.9	22.0	24.2	26.5	28.8	31.3	33.7	36.3	38.9	44.4	50.2	53.2	62.5	69.1		
6 000	14.4	14.4	18.1	20.1	22.2	24.3	26.5	28.8	31.1	33.5	36.0	41.1	46.5	49.3	58.2	64.4		

### Width Factor

Belt width mm	15	25	40	60
Width Factor	1.00	1.79	3.06	4.86

 Belt Types and Dimensions P20

 Selection and Design P39

· notes;

The xxx area makes the belt life shorter and should be avoided.

The pulley speed increases to 33 m/s or over in the xxx area and therefore the pulleys must be kept in good balance.



## UP14M-HC

### Standard Transmission Capacity (Belt width 40 mm)

Number of teeth of small pulley																	kW
Pitch circle diameter mm		28	30	32	34	36	38	40	42	44	46	48	50	56	60	64	72
Small pulley revolution r/min	20	1.0	1.1	1.1	1.2	1.3	1.4	1.5	1.5	1.6	1.7	1.8	1.9	2.1	2.2	2.4	2.7
	40	1.9	2.0	2.2	2.3	2.5	2.7	2.8	3.0	3.1	3.4	3.5	3.7	4.1	4.4	4.7	5.3
	60	2.7	3.1	3.3	3.5	3.8	4.0	4.2	4.4	4.7	4.9	5.1	5.4	6.0	6.5	6.9	7.8
	100	4.5	4.9	5.2	5.6	6.0	6.4	6.2	7.1	7.4	7.9	8.3	8.6	9.7	10.4	11.1	12.6
	200	8.3	9.0	9.7	10.4	11.3	11.9	12.6	13.3	14.0	14.6	15.3	16.1	18.1	19.4	20.9	23.6
	400	15.2	16.5	17.8	19.0	20.3	21.5	22.8	24.0	25.2	26.5	27.7	28.9	32.5	35.0	37.4	42.3
	500	18.4	19.9	21.5	22.9	24.5	26.0	27.4	28.9	30.3	31.8	33.3	34.8	39.1	42.0	45.0	50.7
	600	21.6	23.4	25.1	26.8	28.7	30.3	32.1	33.7	35.5	37.2	39.0	40.7	45.6	49.0	52.5	59.2
	800	27.8	30.2	32.4	34.6	36.9	39.1	41.3	43.5	45.5	48.0	50.1	52.4	58.9	63.3	67.7	76.4
	1 000	33.2	36.1	38.8	41.6	44.6	47.3	50.0	52.7	55.4	58.2	61.0	63.8	71.7	77.1	82.6	93.3
	1 200	39.0	42.5	45.7	49.1	52.6	55.7	59.0	62.2	65.4	68.7	72.0	75.2	84.6	91.1	97.5	110.1
	1 400	44.7	48.8	52.6	56.5	60.6	64.3	68.0	71.8	75.5	79.4	83.2	87.1	97.9	105.4	112.9	127.6
	1 450	46.1	50.3	54.2	58.2	62.6	66.4	70.2	74.1	78.0	81.9	85.8	89.8	101.2	108.9	116.7	131.9
	1 500	47.4	51.8	55.9	60.0	64.4	68.5	72.4	76.4	80.5	84.5	88.6	92.8	104.4	112.4	120.5	136.2
	1 600	49.4	54.4	58.7	63.1	68.1	72.4	76.6	80.9	85.3	89.8	94.2	98.7	111.2	119.8	128.6	145.5
1 750	52.1	57.8	62.7	67.6	73.3	80.9	82.8	87.6	92.5	97.4	102.3	107.4	121.3	130.8	140.6	159.3	
1 800	53.5	59.3	64.4	69.5	75.4	80.2	85.2	90.1	95.1	100.3	105.4	110.6	124.8	134.8	144.9	164.2	
2 000	58.5	65.3	71.0	76.8	83.6	89.1	94.6	100.2	105.8	111.6	117.5	123.5	139.4	150.6	162.1	183.9	
2 400	67.6	76.2	83.1	90.5	99.0	105.7	112.5	119.4	126.4	133.7	140.9	148.3	167.9	181.7	195.7	222.4	
3 000					118.7	127.0	135.5	144.0	152.7	161.8	170.9	180.2	204.4	221.6	239.2	272.2	
3 600							136.2	146.1	156.1	166.3	176.5	187.0	218.5	239.5	260.5	301.5	
4 000								164.0			177.8	192.1	222.9	247.1	272.4	316.4	

### Standard Transmission Torque (Belt width 40 mm)

Number of teeth of small pulley																	N · m
Pitch circle diameter mm		28	30	32	34	36	38	40	42	44	46	48	50	56	60	64	72
Small pulley revolution r/min	20	483	532	532	580	629	677	725	725	774	822	870	919	1 015	1 064	1 160	1 305
	40	461	485	533	558	606	655	679	727	752	800	824	873	970	1 043	1 115	1 261
	60	437	486	518	551	599	631	664	696	745	777	810	858	955	1 036	1 101	1 247
	100	428	467	497	535	574	613	594	682	711	750	789	818	925	993	1 061	1 207
	200	395	430	464	498	537	566	601	635	669	698	732	767	864	928	996	1 128
	400	362	394	424	453	485	514	544	573	602	632	661	690	776	835	894	1 009
	500	351	380	410	437	469	496	523	551	578	608	635	665	747	802	859	969
	600	343	373	399	427	456	482	510	536	564	592	620	647	726	780	836	942
	800	332	360	387	413	441	467	492	519	543	572	598	625	702	755	808	911
	1 000	317	344	371	397	426	451	477	503	529	555	582	609	684	736	788	891
	1 200	310	338	364	390	419	443	469	495	521	546	573	598	673	724	776	876
	1 400	305	333	359	385	413	438	464	489	515	541	567	594	668	719	770	870
	1 450	303	331	357	383	412	437	462	488	514	539	565	591	666	717	768	868
	1 500	302	330	355	382	410	436	461	486	512	538	564	590	664	715	767	867
	1 600	294	324	350	376	406	432	457	483	509	535	562	589	663	715	767	868
1 750	284	315	342	369	400	442	451	478	504	531	558	586	661	714	767	869	
1 800	284	314	341	369	400	425	452	478	504	532	559	587	662	715	768	871	
2 000	279	312	339	367	399	425	452	478	505	533	561	589	665	719	774	878	
2 400	269	303	331	360	394	420	447	475	503	532	560	590	668	723	778	884	
3 000					378	404	431	458	486	515	544	573	650	705	761	866	
3 600							361	387	414	441	468	496	579	635	691	799	
4 000								391	424	451	478	506	592	650	707	817	

### Width Factor

Belt width mm	40	60	80	100	120
Width Factor	1.00	1.59	2.20	2.84	3.50

Belt Types and Dimensions	P21
Selection and Design	P39

· notes;

The **xxx** area makes the belt life shorter and should be avoided.

The pulley speed increases to 33 m/s or over in the **xxx** area and therefore the pulleys must be kept in good balance.

# TSUBAKI BELT TENSION METER T-ACE



The Tsubaki belt tension meter “T-ACE” is a sound wave formula belt tension meter that correctly and accurately measures the installation tension of a belt without touching it.

The control of the belt installation tension is very important in ensuring that the belt works at its fullest capacity.

The belt tension meter “T-ACE” developed by Tsubaki’s original technology is an economical instrument with all the necessary functions incorporated neatly.

## Features

### ■ Light weight and compact

The mass of the main unit is as light as 160 g and its size is compact for easy carrying.

### ■ Large LCD screen

Since measurement results and measuring conditions are shown in the same screen, they can easily be checked while taking measurements.

### ■ Memory function

Up to 10 measuring conditions can be kept in memory, which can be invoked by simple operation.

### ■ Unit display changeover

The unit of measurement results can be changed over between “N” and “Hz” as desired.

### ■ Auto power-off function

When the meter is not operated for 3 minutes, the power will automatically be turned off.



## Specifications

Model	<b>BDTM101</b>
Measuring range	30~600Hz、0.1~9999N (Indication possible area)
Belt span length	0.001~9.999 m (Indication possible area)
Unit mass	0.001~9.999 kg/m (Indication possible area)
Working temperature	-10~60°C
Power supply	Dry Cell AAAx4
Mass/dimensions	160g (Main body) · L162xW61.6xD30 mm



See the separate catalog for details.



## PX BELT

### Standard transmission capacity

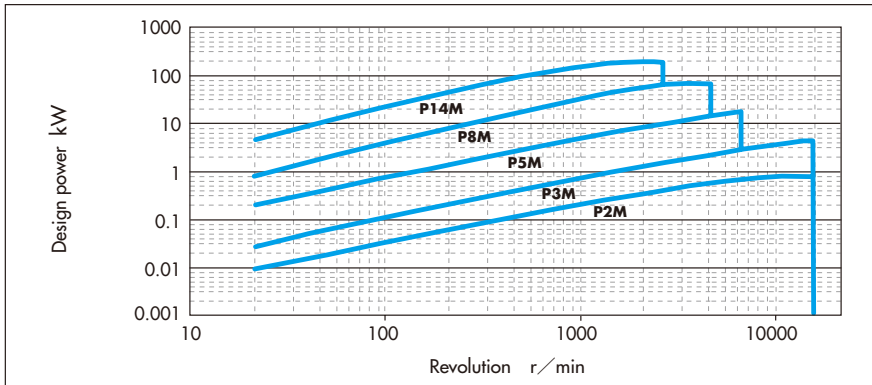

### Standard transmission torque

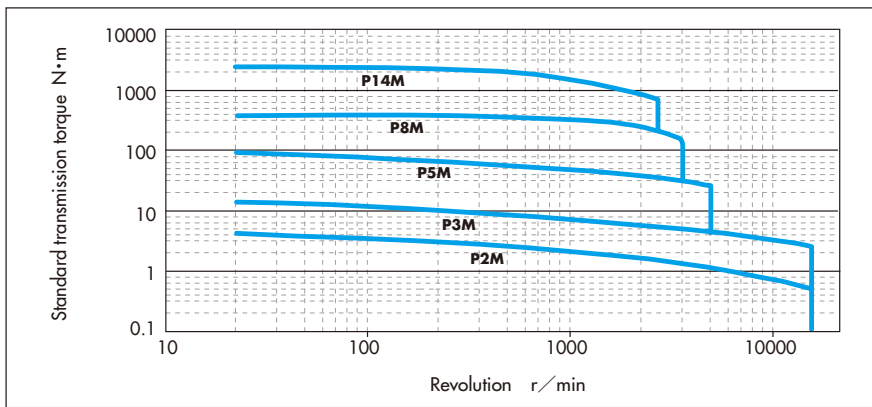

## ULTRA PX HC TYPE

### Standard transmission capacity

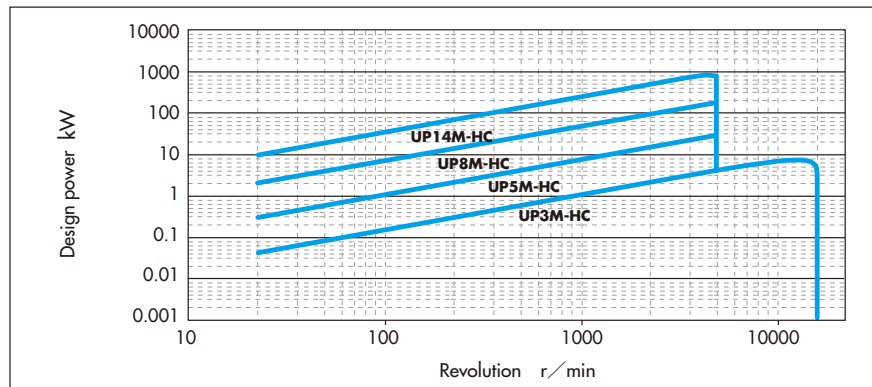

### Standard transmission torque

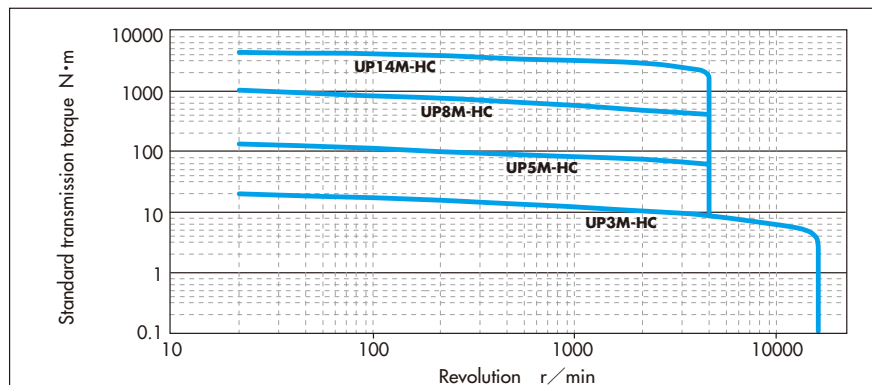





## FORMULAE LIST

Item		Formulae	Explanation of sign
Pitch circle diameter	$D_p$ mm	$D_p = \frac{N \times p}{\pi}$	$N$ : Number of teeth of pulley $p$ : Belt pitch mm
Belt speed	$V$ m/s	$V = \frac{\pi D_p \times n}{1000 \times 60}$	$D_p$ : Pitch circle diameter of pulley mm $n$ : Revolution of pulley r/min
Tension required for drive	$F_a$ N {kgf}	$F_a = \frac{9.8 \times 102 \times P}{V} = \frac{2T}{\left(\frac{D_p}{1000}\right)}$ $\left\{ \begin{array}{l} \text{Gravity unit :} \\ F_a = \frac{102 \times P}{V} = \frac{2T}{\left(\frac{D_p}{1000}\right)} \end{array} \right\}$	$P$ : Power kW $V$ : Belt speed m/s $T$ : Torque N · m {kgf · m} $D_p$ : Pitch circle diameter of pulley mm
Power	$P$ kW	$P = \frac{F_a \times V}{1000} = \frac{T \times n}{974 \times 9.8}$ $\left\{ \begin{array}{l} \text{Gravity unit :} \\ P = \frac{F_a \times V}{102} = \frac{T \times n}{974} \end{array} \right\}$	$F_a$ : Tension required for drive N {kgf} $V$ : Belt speed m/s $T$ : Torque N · m {kgf · m} $n$ : Revolution r/min
Torque	$T$ N · m {kgf · m}	$T = \frac{9.8 \times 974 \times P}{n}$ $\left\{ \begin{array}{l} \text{Gravity unit :} \\ T = \frac{974 \times P}{n} \end{array} \right\}$	$P$ : Power kW $n$ : Revolution r/min
Torque due to flywheel effect	$T_f$ N · m {kgf · m}	$T_f = \frac{I \pi (n_2 - n_1)}{30t}$ $\left\{ \begin{array}{l} \text{Gravity unit :} \\ T_f = \frac{GD^2 \times (n_2 - n_1)}{375 \times t} \end{array} \right\}$	$I$ : Moment of inertia $kg \cdot m^2$ $n_1$ : Revolution before acceleration (deceleration) r/min $n_2$ : Revolution after acceleration (deceleration) r/min $t$ : Time from $n_1$ to $n_2$ s $GD^2$ : Flywheel effect {kgf · m <sup>2</sup> }
Center distance	$C$ mm	$C = \frac{B + \sqrt{B^2 - 2(D_p - dp)^2}}{4}$ $B = L - 1.57(D_p + dp)$	$L$ : Belt length mm $D_p$ : Pitch circle diameter of large pulley mm $dp$ : Pitch circle diameter of small pulley mm
Belt length	$L$ mm	$L = 2C + 1.57(D_p + dp) + \frac{(D_p - dp)^2}{4C}$	$D_p$ : Pitch circle diameter of large pulley mm $dp$ : Pitch circle diameter of small pulley mm $C$ : Center distance mm
Number of meshing teeth of small pulley	$Z_m$	$Z_m = N \times \frac{\phi}{360^\circ}$ $\phi = 180^\circ - \frac{57^\circ (D_p - dp)}{C}$	$N$ : Number of teeth of small pulley $\phi$ : Belt contact angle to small pulley degrees degrees $D_p$ : Pitch circle diameter of large pulley mm $dp$ : Pitch circle diameter of small pulley mm $C$ : Center distance mm



## SELECTION METHOD

### Design Support Site

See the procedures that begin with this page for timing belt selection. Our homepage provides Tsubaki Timing Belt & Pulley Design Support Services that allow selection on PCs. Customers can select belts and pulleys and carry out layout calculations by inputting simple values on the screen. Customers need not install any software or carry out user registration.

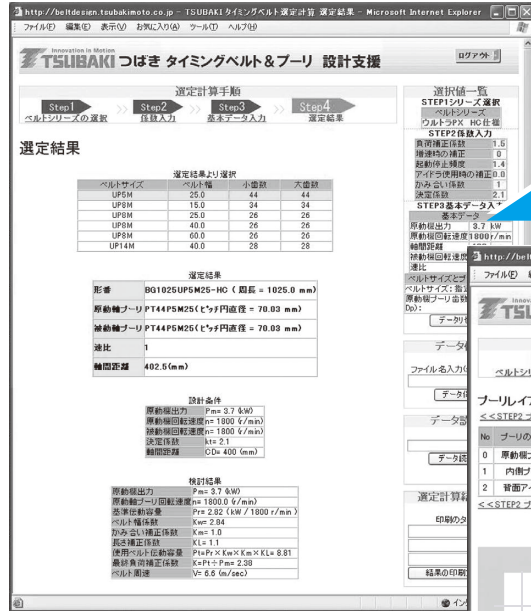

### Selection calculation function

Optimum belts that meet the conditions are calculated automatically if simple use conditions are input.

### Layout calculation function

Belt length and pulley layout can be examined in the XY-coordinate form.

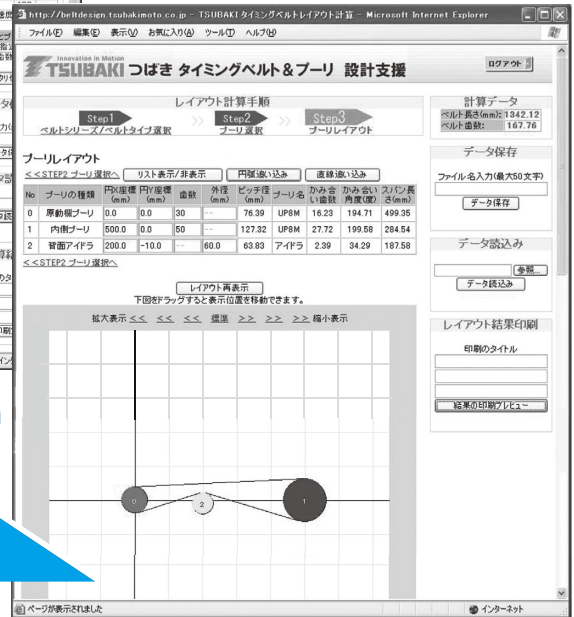

### Type of selection

Timing belts can be selected by the following methods. Use a method that suits your requirements.

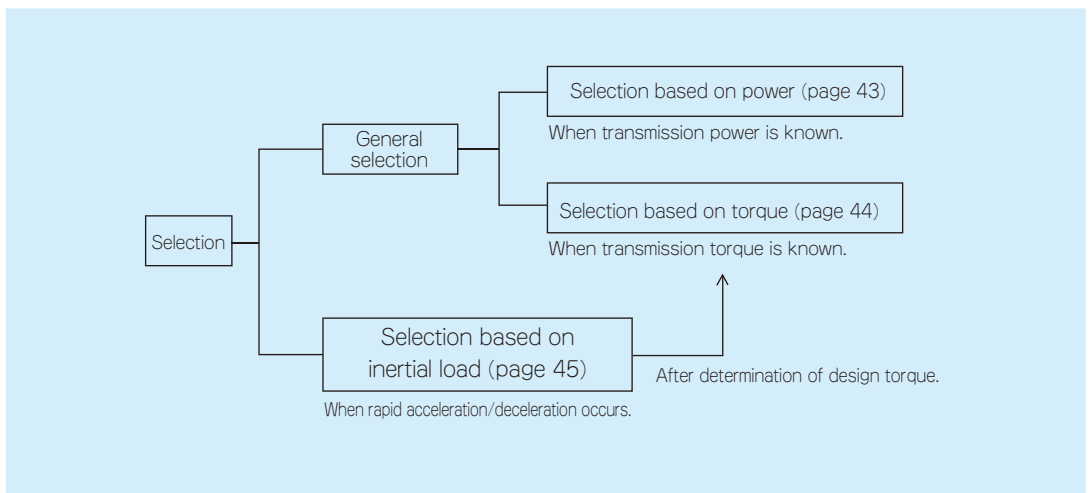



### CORRECTION FACTORS

#### Correction Factors

**Table 1: Load correction factor ( $K_o$ )**

Ratio of max. load output to motor rated output		$\leq 200\%$			201%~249%			250% $\leq$		
		<3	3~10	10<	<3	3~10	10<	<3	3~10	10<
Type of load and examples of application	Run hours per day h									
	Relatively smooth drive Example: Measuring instruments, medical equipment, agitators	1.2	1.3	1.4	1.3	1.4	1.4	1.4	1.5	1.6
	Drive with slight shock Example: Injection molding machines, machine tools, conveyors, pumps	1.3	1.4	1.5	1.4	1.5	1.6	1.5	1.6	1.7
	Drive with large shock Example: Robots, high-speed press machines, intermittently driven conveyors	1.4	1.5	1.6	1.6	1.6	1.7	1.7	1.7	1.8

For drive that is subjected to very strong shock, a factor greater than 1.8 may be required. For such applications, please contact us.

**Table 2: Correction factor when idler is used ( $K_i$ )**

Idler mounted on	Inside	Outside
Slack side of belt	0	+0.1
Tension side of belt	+0.1	+0.2

**Table 3: Correction factor for speed increase ( $K_s$ )**

Increase ratio	Correction factor
1 and over, up to 1.25	0
1.25 and over, up to 1.75	+0.2
1.75 and over, up to 2.5	+0.3
2.5 and over, up to 3.5	+0.4
3.5 and over	+0.5

**Table 4: Start-stop frequency correction factor ( $K_a$ )**

Frequency of start-stop per day	$\leq 10$	11~100	101~999	1000 $\leq$
Ratio of max. output to motor rated output	$\leq 200\%$	1.2	1.3	1.4
	201%~249%	1.3	1.4	1.5
	250% $\leq$	1.4	1.6	1.7

**Table 5: Belt length correction factor ( $K_L$ )**

Belt length mm	$\leq 200$	201~300	301~450	451~600	601~900	901~1300	1301~1800	1801 $\leq$
Type (Pitch)								
<b>P2M</b>	0.8	0.9	1.0	1.1	1.2	1.2	1.2	1.2
<b>P3M•UP3M</b>	0.8	0.9	1.0	1.1	1.2	1.2	1.2	1.2
<b>P5M•UP5M</b>	—	0.8	0.8	0.9	1.0	1.1	1.2	1.2
<b>P8M•UP8M</b>	—	—	0.8	0.8	0.9	1.0	1.1	1.2
<b>P14M•UP14M</b>	—	—	—	—	—	0.9	1.0	1.1

**Table 6: Meshing correction factor ( $K_m$ )**

Number of meshing teeth of small pulley $Z_m$	6 or over	5	4
Meshing correction factor	1.0	0.7	0.5



### SELECTION BASED ON POWER

#### Parameters required for selection

The parameters required for selection are as follows. Determine each condition.

- Output of motor kW, revolution of output shaft r/min, shaft diameter
- Speed ratio
- Type, revolution r/min, shaft diameter of driven machine
- Use or nonuse of idler
- Center distance
- Other conditions (layout restriction, etc.)
- Hours of use and frequency of start-stop per day

#### Determination of design power

Calculate the design power as follows:

$$Pd = Pk \times (Ko + Ki + Ks) \times Ka \times Ke^{**}$$

$Pd$  : Design power kW

$Pk$  : Transmission power\* kW

$Ko$  : Load correction factor Table 1 on page 42

$Ki$  : Correction factor when idler is used Table 2 on page 42

$Ks$  : Correction factor for speed increase Table 3 on page 42

$Ka$  : Start-stop frequency correction factor Table 4 on page 42

$Ke$  : Operation environment coefficient 1.2

\* The transmission power means motive power of transmission. The motor output is used normally. If the actual transmission power (with the actual load) is known, use it.  
 \*\* Multiply the operation environment coefficient ( $Ke$ ) of 1.2 if the oil-proof film of the ultra PX belt is used in an environment subject to oil splashes.

#### Determination of belt size and number of teeth of pulleys

- (1) Referring to the simplified selection tables (pages 39), tentatively select a belt size based on the design power and small pulley revolution.
- (2) Referring to the standard transmission capacity tables (pages 29 – 37), tentatively select a belt width and the number of teeth of the small pulley. For selection, take the following precautions:
  - Select the number of teeth of the small pulley from areas other than the colored areas in the standard transmission capacity tables.
  - Select a small pulley that meets the "pitch circle diameter > belt width."
  - Verify that the bore usable range of the small pulley satisfies the shaft diameter.
- (3) Determine the number of teeth of the large pulley based on the number of teeth of the small pulley and the speed ratio. Verify the bore diameter to use also.

#### Selection of belt length and center distance

- (1) Calculate an approximate belt length ( $L'$ ) and select a belt of the length that is closest to the approximate length from the list of belt types.

$$L' = 2C + 1.57(Dp + dp) + \frac{(Dp - dp)^2}{4C}$$

$L'$  : Approximate belt length mm

$C$  : Center distance mm

$Dp$  : Pitch circle diameter of large pulley mm

$dp$  : Pitch circle diameter of small pulley mm

- (2) Calculate the center distance ( $C$ ) using the selected belt length ( $L$ ).

$$C = \frac{B + \sqrt{B^2 - 2(Dp - dp)^2}}{4}$$

$$B = L - 1.57(Dp + dp)$$

$L$  : Belt length mm

#### Correction for the number of meshing teeth

The use of a pulley the number of meshing teeth of which is less than 6 is not recommended, but if such a pulley needs to be used, correction for the number of meshing teeth is necessary. After obtaining the number of meshing teeth, determine a meshing correction factor referring to Table 6 on page 42. The engagement angles of the drive pulley and idler pulley should be 120° or more and 90° or more, respectively.

$$Zm = N \times \frac{\phi}{360^\circ}$$

$Zm$  : Number of meshing teeth of small pulley

$N$  : Number of teeth of small pulley

$\phi$  : Belt contact angle to small pulley degrees

$Dp$  : Pitch circle diameter of large pulley mm

$dp$  : Pitch circle diameter of small pulley mm

$$\phi = 180^\circ - \frac{57^\circ (Dp - dp)}{C}$$

#### Verification of belt width

Verify the belt width that satisfies the design power.

$$Pd \leq Pu \times Kw \times Km \times Kl$$

$Pd$  : Design power kW

$Pu$  : Standard transmission capacity kW

$Kw$  : Belt width factor

$Km$  : Meshing correction factor Table 6 on page 42

$Kl$  : Belt length correction factor Table 5 on page 42

$$Kw \geq \frac{Pd}{Pu \times Km \times Kl}$$



### SELECTION BASED ON TORQUE

#### Parameters required for selection

The parameters required for selection are as follows. Determine each condition.

- Output shaft torque of motor  $N \cdot m$ , output shaft revolution  $r/min$ , shaft diameter
- Type, revolution  $r/min$ , shaft diameter of driven machine
- Center distance
- Hours of use and frequency of start-stop per day
- Speed ratio
- Use or nonuse of idler
- Other conditions

#### Determination of design torque

Calculate the design torque as follows:

$$P_t = P_m \times (K_o + K_i + K_s) \times K_a \times K_e^{**}$$

- $P_t$  : Design torque  $N \cdot m$
- $P_m$  : Transmission torque  $N \cdot m$
- $K_o$  : Load correction factor Table 1 on page 42
- $K_i$  : Correction factor when idler is used Table 2 on page 42
- $K_s$  : Correction factor for speed increase Table 3 on page 42
- $K_a$  : Start-stop frequency correction factor Table 4 on page 42
- $K_e$  : Operation environment coefficient 1.2

\* Multiply the operation environment coefficient ( $K_e$ ) of 1.2 if the oil-proof film of the ultra PX belt is used in an environment subject to oil splashes.

#### Determination of belt size and number of teeth of pulleys

- (1) Referring to the simplified selection tables (pages 39), tentatively select a belt size based on the design torque and small pulley revolution.
- (2) Referring to the standard transmission torque tables (pages 29-37), tentatively select a belt width and the number of teeth of the small pulley. For selection, take the following precautions:
  - Select the number of teeth of the small pulley from areas other than the colored areas in the standard transmission torque tables.
  - Select a small pulley that meets the "pitch circle diameter > belt width."
  - Verify that the bore usable range of the small pulley satisfies the shaft diameter.
- (3) Determine the number of teeth of the large pulley based on the number of teeth of the small pulley and the speed ratio. Verify the bore diameter to use also.

#### Selection of belt length and center distance

- (1) Calculate an approximate belt length ( $L'$ ) and select a belt of the length that is closest to the approximate length from the list of belt types.

$$L' = 2C + 1.57(D_p + d_p) + \frac{(D_p - d_p)^2}{4C}$$

- $L'$  : Approximate belt length  $mm$
- $C$  : Center distance  $mm$
- $D_p$  : Pitch circle diameter of large pulley  $mm$
- $d_p$  : Pitch circle diameter of small pulley  $mm$

- (2) Calculate the center distance ( $C$ ) using the selected belt length ( $L$ ).

$$C = \frac{B + \sqrt{B^2 - 2(D_p - d_p)^2}}{4}$$

$$B = L - 1.57(D_p + d_p)$$

$L$  : Belt length  $mm$

#### Correction for the number of meshing teeth

The number of engaged pulley teeth is preferably 6 or more. If it is less than 6, carry out compensation based on the number of engaged teeth. Find the number of engaged teeth and decide the engagement compensation coefficient using Table 6 on page 42. The engagement angles of the drive pulley and idler pulley should be  $120^\circ$  or more and  $90^\circ$  or more, respectively.

$$Z_m = N \times \frac{\phi}{360^\circ}$$

$$\phi = 180^\circ - \frac{57^\circ (D_p - d_p)}{C}$$

- $Z_m$  : Number of meshing teeth of small pulley
- $N$  : Number of teeth of small pulley
- $\phi$  : Belt contact angle to small pulley  $degrees$
- $D_p$  : Pitch circle diameter of large pulley  $mm$
- $d_p$  : Pitch circle diameter of small pulley  $mm$
- $C$  : Center distance  $mm$

#### Verification of belt width

Verify the belt width that satisfies the design torque.

$$P_t \leq P_r \times K_w \times K_m \times K_L$$

$$K_w \geq \frac{P_t}{P_r \times K_m \times K_L}$$

- $P_t$  : Design torque  $N \cdot m$
- $P_r$  : Standard transmission torque  $N \cdot m$
- $K_w$  : Belt width factor
- $K_m$  : Meshing correction factor Table 6 on page 42
- $K_L$  : Belt length correction factor Table 5 on page 42



## SELECTION BASED ON INERTIAL LOAD

### Parameters required for selection

The parameters required for selection are as follows. Determine each condition.

- (1) Rotating body  
Shape, dimensions, mass, revolution, acceleration (deceleration) time, shaft diameter, center distance, run hours per day, start-stop frequency, speed ratio, use or nonuse of an idler and other conditions.
- (2) Linear moving body  
Pulley pitch circle diameter, mass of a linear moving body, supporting method, coefficient of friction of supporting mechanism, moving speed, acceleration (deceleration) time, shaft diameter, center distance, run hours per day, start-stop frequency, speed ratio, use or nonuse of an idler and other conditions.

### Calculation of moment of inertia

Calculate the moment of inertia as follows:

- (1) Rotating body
  - Solid cylinder  
 $I = \frac{1}{8} mD^2$
  - Hollow cylinder  
 $I = \frac{1}{8} m(D^2 + d^2)$
  - Rectangular cross section  
 $I = \frac{1}{12} m(a^2 + b^2)$
  - Eccentric rotating body  
 $I = \frac{1}{8} mD^2 + me^2$
- (2) Linear moving body  
 $I = \frac{1}{4} mDp^2$
- (3) Ball screw drive  
 $I = \frac{1}{4} m \left(\frac{l}{\pi}\right)^2$
- (4) Total moment of inertia  
 $\Sigma I = (I_1 + I_2 + \dots) R^2$

$I$  : Moment of inertia of a body  $\text{kg} \cdot \text{m}^2$   
 $\Sigma I$  : Total moment of inertia  
 $m$  : Mass of a rotating or linear moving body  $\text{kg}$   
 $D$  : Outside diameter of a rotating body  $\text{m}$   
 $d$  : Inside diameter of the hollow of a rotating body  $\text{m}$   
 $a$  : Length of a side of the rectangular cross section  $\text{m}$   
 $b$  : Length of a side of the rectangular cross section  $\text{m}$   
 $e$  : Distance of eccentricity  $\text{m}$   
 $Dp$  : Pulley pitch circle diameter  $\text{m}$   
 $l$  : Lead of screw  $\text{m}$   
 $R$  : Reduction ratio (Number of teeth of drive pulley / number of teeth of driven pulley)

※Total the moment of inertia of all moving bodies (including the driven pulley) that are drive by the belt by the equation shown on the left side.

### Calculation of acceleration (deceleration) torque

Calculate the acceleration (deceleration) torque as follows:

$$Pa = \frac{\Sigma I \times (n_2 - n_1)}{9.55 \times ta}$$

$Pa$  : Acceleration (deceleration) torque  $\text{N} \cdot \text{m}$   
 $n_1$  : Revolution before acceleration (deceleration)  $\text{r/min}$   
 $n_2$  : Revolution after acceleration (deceleration)  $\text{r/min}$   
 $ta$  : Acceleration (deceleration) time  $\text{s}$

### Calculation of continuous load torque

Calculate the continuous load torque as follows:

(1) Horizontal movement  
 $Pc = 4.9 \times \mu Dp$

(2) Vertical movement  
 $Pc = 4.9 \times m Dp$

$Pc$  : Continuous load torque  $\text{N} \cdot \text{m}$   
 $\mu$  : Coefficient of friction of moving body supporting mechanism

### Determination of design torque

Calculate the design torque as follows. For  $Ko$  and  $Ka$ , use values in the following tables:

$$Pt = (Pa + Pc) \times (Ko + Ki + Ks) \times Ka \times Ke^*$$

$Pt$  : Design torque  $\text{N} \cdot \text{m}$   
 $Pa$  : Acceleration (deceleration) torque  $\text{N} \cdot \text{m}$   
 $Pc$  : Continuous load torque  $\text{N} \cdot \text{m}$   
 $Ko$  : Load correction factor Left-side figure  
 $Ki$  : Correction factor when idler is used Table 2 on page 42  
 $Ks$  : Correction factor for speed increase Table 3 on page 42  
 $Ka$  : Start-stop frequency correction factor Left-side figure  
 $Ke$  : Operation environment coefficient 1.2

Run hours per day h	< 3	3 ~ 10	10 <
$Ko$	1.2	1.3	1.5

Frequency of start/stop per day	$\leq 10$	11 ~ 100	101 ~ 999	1000 $\leq$
$Ka$	1.1	1.2	1.3	1.5

\* Multiply the operation environment coefficient ( $Ke$ ) of 1.2 if the oil-proof film of the ultra PX belt is used in an environment subject to oil splashes.

※For the following steps, return to "Determination of belt size and number of teeth of pulleys" on page 43.



### AN EXAMPLE OF SELECTION CALCULATION (BASED ON POWER)

#### Parameters required for selection

The parameters required for selection are as follows:

Item	Description
Motor output, revolution, shaft diameter	5.5kW (peak torque 200%), 1450 r/min, 32 mm
Type, revolution, shaft diameter of driven machine	Pump, 920 r/min, 30 mm
Center distance	415 mm
Run hours per day, start-stop frequency	12 hours/day, 100 times/day
Speed ratio	1 : 1.58 reduction
Use or nonuse of idler	On the back of the slack side
Other conditions	Small pulley to be 100 mm or less in OD for layout reason.

#### Determination of design power

Obtain the correction factors appropriate for the conditions of use from the tables on page 42 and determine the design power.

Load correction factor ( $K_o$ ) ..... 1.5  
 Correction factor when idler is used ( $K_i$ ) ..... 0.1  
 Correction factor for speed increase ( $K_s$ ) ..... 0  
 Start-stop frequency correction factor ( $K_a$ ) ..... 1.3  
 Design power:  $d = Pk \times (K_o + K_i + K_s) \times K_a = 5.5 \times (1.5 + 0.1 + 0) \times 1.3 = 11.44$   
 Thus, the design power is 11.44 kW.

#### Determination of belt size and number of teeth of pulleys

- (1) Tentatively determine a belt size from the simplified selection tables (page 39). Here, tentatively select "P8M" from the design power (11.44 kW) and motor revolution (1450 r/min).
- (2) In consideration of the speed ratio, shaft diameters of the motor and driven machine and other conditions, select a belt width and the number of teeth of a pulley from the standard transmission capacity table (page 32). Here, select 28 teeth ( $d_p=71.30$  mm) and 44 teeth ( $D_p=112.05$  mm) of P8M60 (belt width 60 mm). For the dimensions of the pulleys, see pages 51 - 57.

#### Determination of belt length and center distance

- (1) Calculate an approximate belt length ( $L'$ ).

$$L' = 2C + 1.57(D_p + d_p) + \frac{(D_p - d_p)^2}{4C} = 2 \times 415 + 1.57(112.05 + 71.30) + \frac{(112.05 - 71.30)^2}{4 \times 415} = 1118.86 \text{ mm}$$

The belt which is closest to this approximate length is "1120P8M" (140 teeth) from the list of types and dimensions (page 17).

- (2) Calculate the center distance ( $C$ ).

$$B = L - 1.57(D_p + d_p) = 1120 - 1.57(112.05 + 71.30) = 832.14$$

$$C = \frac{B + \sqrt{B^2 - 2(D_p - d_p)^2}}{4} = \frac{832.14 + \sqrt{832.14^2 - 2(112.05 - 71.30)^2}}{4} = 415.57 \text{ mm}$$

#### Correction for the number of meshing teeth

Obtain the number of teeth of the belt that mesh with the small pulley and determine the meshing correction factor.

$$\phi = 180^\circ - \frac{57^\circ (D_p - d_p)}{C} = 180^\circ - \frac{57^\circ (112.05 - 71.30)}{415.57} = 174.41^\circ$$

$$Z_m = N \times \frac{\phi}{360^\circ} = \frac{28 \times 174.41}{360^\circ} = 13.6 \text{ teeth}$$

Thus, the meshing correction factor is 1.0 from the table on page 42.

#### Determination of belt width

Finally determine the belt width that satisfies the design power.

$$K_w \geq \frac{Pd}{P_u \times K_m \times K_L} = \frac{11.44}{3.06 \times 1.0 \times 1.0} = 3.74$$

Thus, the belt that satisfies the width factor is P8M60 (belt width 60 mm).

#### Results of selection

Belt : BG1120P8M60  
 Small pulley : PT28P8M60AF or BF  
 Large pulley : PT44P8M60AF or BF  
 Center distance : 415.57 mm



### AN EXAMPLE OF SELECTION CALCULATION (BASED ON INERTIAL LOAD)

#### Parameters required for selection

The parameters required for selection are as follows:

Item	Description
	(Machine tool table drive)
Pulley pitch circle diameter	50 mm or less
Mass of linear moving body	50 kg
Supporting method and coefficient of friction of supporting mechanism	LM guide, coefficient of friction $\mu = 0.1$
Moving speed	1000 r/min
Acceleration (deceleration) time	0.3 s
Shaft diameter	20 mm
Center distance	1400 mm
Run hours per day, start-stop frequency	12 hours/day, 1000 times/day
Speed ratio	1 : 1
Use or nonuse of idler	None
Other conditions	None

#### Calculation of moment of inertia

First, obtain the moment of inertia. For the linear moving body, the following equation applies. Based on the above conditions, tentatively select the pulley "30P5M" (number of teeth 30,  $D_p = 47.75$  mm).

$$I = \frac{1}{4} m D_p^2 = \frac{1}{4} \times 50 \times 0.04775^2 = 0.0285 \text{ kg} \cdot \text{m}^2$$

#### Calculation of acceleration (deceleration) torque and continuous load torque

Obtain the acceleration (deceleration) torque and continuous load torque as follows:

$$\text{Acceleration (deceleration) torque} \quad P_a = \frac{I \times (n_2 - n_1)}{9.55 \times t_a} = \frac{0.0285 \times (1000 - 0)}{9.55 \times 0.3} = 9.95 \text{ N} \cdot \text{m}$$

$$\text{Continuous load torque} \quad P_c = 4.9 \times m \mu D_p = 4.9 \times 50 \times 0.1 \times 0.04775 = 1.17 \text{ N} \cdot \text{m}$$

#### Determination of design torque

Obtain the design torque by multiplying a total of the acceleration (deceleration) torque and continuous load torque by each correction factor.

$$P_t = (P_a + P_c) \times (K_o + K_i + K_s) \times K_a = (9.95 + 1.17) \times (1.5 + 0 + 0) \times 1.5 = 25.02 \text{ N} \cdot \text{m}$$

After the determination of the design torque, follow "General selection - Selection based on torque."

#### Determination of belt size and number of teeth of pulleys

- (1) Tentatively select a belt size from the simplified selection tables (page 39). Here, tentatively select "UP5M" from the design torque (25.02 N·m) and motor revolution (1000 r/min).
- (2) In consideration of the pulley pitch circle diameter, speed ratio, shaft diameter and other conditions, select a belt width and the number of teeth of the pulley from the standard transmission torque table (page 35). Here, select 30 teeth ( $D_p = 47.75$  mm) of UP5M25 (belt width 25 mm). For the dimensions of the pulleys, see pages 51-57.

#### Determination of belt length and center distance

- (1) Calculate an approximate belt length ( $L'$ ).

$$L' = 2C + 1.57(D_p + d_p) + \frac{(D_p - d_p)^2}{4C} = 2 \times 1400 + 1.57(47.75 + 47.75) + \frac{(47.75 - 47.75)^2}{4 \times 1400} = 2950 \text{ mm}$$

The belt which is closest to this approximate length is "3050UP5M" (610 teeth) from the list of types and dimensions (page 19).

- (2) Calculate the center distance ( $C$ ).

$$B = L - 1.57(D_p + d_p) = 3050 - 1.57(47.75 + 47.75) = 2900$$

$$C = \frac{B + \sqrt{B^2 - 2(D_p - d_p)^2}}{4} = \frac{2900 + \sqrt{2900^2 - 2(47.75 - 47.75)^2}}{4} = 1450 \text{ mm}$$

#### Correction for the number of meshing teeth

Obtain the number of teeth of the belt that mesh with the small pulley and determine the meshing correction factor. Since the speed ratio is 1:1, the number of meshing teeth is a half of 30 teeth, which is 15 teeth. Thus, the meshing correction factor is 1.0.

#### Determination of belt width

Finally confirm the belt width that satisfies the design torque.

$$K_w \geq \frac{P_t}{P_r \times K_m \times K_L} = \frac{25.02}{9.37 \times 1.0 \times 1.2} = 2.23$$

Thus, the belt that satisfies the width factor is UP5M25 (belt width 25 mm).

#### Results of selection

Belt : BG3050UP5M25-HC

Pulley : PT30P5M25AF or BF

Center distance : 1450 mm





## DESIGN REFERENCE

### Installation of guide flanges

The timing belt when running tends to deviate in the axial direction of the pulleys. In order to prevent the timing belt from moving out of the pulleys, guide flanges are installed on the pulleys. The guide flange installation standard is as follows:

#### Horizontal-shaft transmission

Install guide flanges on both sides of either pulley or install a guide flange on one side of one pulley and another flange on the opposite side of the other pulley. (Example 1) Where the pulley center distance is greater than 8 times the outside diameter of the small pulley, install guide flanges on both sides of both pulleys. (Example 2)

(Example 1)

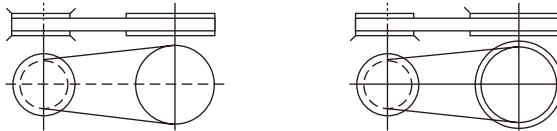

(Example 2)

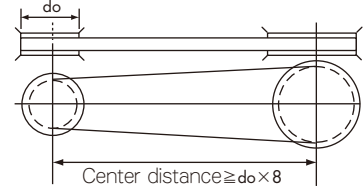

#### Vertical-shaft transmission

Since the belt is likely to disengage downward, install guide flanges on both sides of one pulley and another guide flange on the lower side of the other pulley.

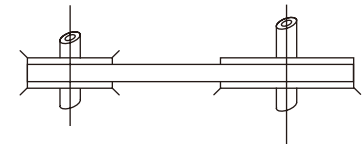

#### Multiple-shaft transmission

Install guide flanges on both sides of every other pulley (Example 1) or install guide flanges on one side of all pulleys alternately (Example 2).

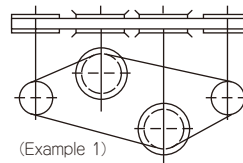

(Example 1)

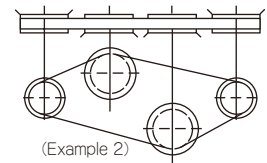

(Example 2)

### Use of an idler

#### An idler is used in the following cases:

- The bearing is stationary and an idler is used for adjustment of the installation tension.
- The speed ratio is large and the number of meshing teeth of the small pulley needs to be increased.
- No belt guide can be used on the drive and driven pulleys.

#### Precautions for using the idler

- The idler must be stationary and as a rule be used on the slack side.
- Note that if the parallelism between the axis of the idler and the axes of both pulleys is poor, the idler may cause the belt to disengage from the pulleys.
- Determine the idler diameter according to the following criteria.

Inside idler.....A timing pulley having the number of teeth greater than the minimum number of teeth of pulley in the following table.  
 Outside idler.....A flat pulley that is greater than 1.2 times the pitch circle diameter of the pulley in the following table and does not have a crown.

#### Minimum number of teeth of pulley for selection of an idler

Revolution Type	r/min			
	Up to and incl. 900	Over 900, up to and incl. 1200	Over 1200, up to and incl. 1800	Over 1800, up to and incl. 3600
<b>P2M</b>	16	16	18	20
<b>P3M•UP3M</b>	14	14	16	18
<b>P5M•UP5M</b>	18	20	24	28
<b>P8M•UP8M</b>	24	26	26	28
<b>P14M•UP14M</b>	28	28	28	34

Note: For revolutions above 3600 r/min, refer to the Standard Transmission Capacity Table.

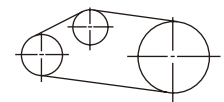

Inside idler

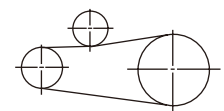

Outside idler



## DESIGN REFERENCE

### Installation tension and axial load

#### ■Belt installation tension

Timing belt drive is meshing type drive, but an adequate installation tension is required to prevent jumping teeth and to ensure smooth drive. A weak installation tension tends to cause mismatching of tooth meshing and a strong tension tends to cause noises, both of which shorten the service life. A sound wave formula belt tension meter that can measure the tension accurately is available. See page 38.

#### ■How to apply an installation tension

1. Accurately establish the parallelism of all shafts including the idler shaft and pulley alignment.
2. Apply a force (F) to the center of the span of the belt.
3. Apply a tension that makes the deflection (δ) of the belt 1.6 mm per 100 mm of span.

#### ■How to obtain the push force (F)

$$F = \frac{T_i + \frac{t \times Y}{L}}{16}$$

F : Push force required for deflection (δ) at the center of the span N {kgf}  
 T<sub>i</sub> : Installation tension N {kgf}  
 Y : Correction factor  
 δ : Deflection mm=0.016 t  
 t : Span length mm

$t = \sqrt{C^2 - \frac{(D_p - d_p)^2}{4}}$   
 C : Center distance mm  
 D<sub>p</sub> : Pitch circle diameter of large pulley mm  
 d<sub>p</sub> : Pitch circle diameter of small pulley mm  
 L : Belt length mm

#### ■List of installation tension

Type	Belt Width mm	Installation Tension T <sub>i</sub> N {kgf}		Correction Factor Y
		Recommended	Max. Value	
P2M	4	5.9 { 0.6 }	7.8 { 0.8 }	0.6 { 0.06 }
	6	9.8 { 1.0 }	13 { 1.3 }	0.9 { 0.09 }
	10	17 { 1.7 }	23 { 2.3 }	1.6 { 0.16 }
P3M	6	20 { 2.0 }	26 { 2.7 }	1.1 { 0.11 }
	10	34 { 3.5 }	46 { 4.7 }	1.9 { 0.19 }
	15	55 { 5.6 }	74 { 7.5 }	3.0 { 0.31 }
UP3M-HC	6	29 { 3.0 }	40 { 4.1 }	21.6 { 2.2 }
	10	54 { 5.5 }	72 { 7.3 }	34.3 { 3.5 }
	15	88 { 9.0 }	118 { 12.0 }	52.0 { 5.3 }
P5M·P5M-W UP5M-HC/HA	10	108 { 11.0 }	147 { 15.0 }	56.9 { 5.8 }
	15	167 { 17.0 }	225 { 23.0 }	82.4 { 8.4 }
	25	304 { 31.0 }	412 { 42.0 }	201 { 20.5 }
P8M·P8M-W	15	225 { 23.0 }	294 { 30.0 }	135 { 13.8 }
	25	382 { 39.0 }	510 { 52.0 }	239 { 24.4 }
	40	657 { 67.0 }	860 { 88.0 }	419 { 42.8 }
UP8M-HC/HA	60	1 040 { 106 }	1 370 { 140.0 }	628 { 64.1 }
	15	177 { 18.0 }	235 { 24.0 }	135 { 13.8 }
	25	304 { 31.0 }	408 { 41.6 }	239 { 24.4 }
P14M	40	530 { 54.0 }	690 { 70.4 }	419 { 42.7 }
	60	834 { 85.0 }	1 100 { 112.0 }	628 { 64.0 }
	40	990 { 101.0 }	1 310 { 134.0 }	502 { 51.2 }
UP14M-HC	60	1 500 { 153.0 }	2 000 { 204.0 }	837 { 85.4 }
	80	2 110 { 215.0 }	2 810 { 286.0 }	1 000 { 102.0 }
	100	2 710 { 276.0 }	3 610 { 368.0 }	1 260 { 128.0 }
UP14M-HC	120	3 340 { 341.0 }	4 450 { 454.0 }	1 680 { 171.0 }
	40	794 { 81.0 }	1 050 { 107.0 }	502 { 51.2 }
	60	1 200 { 122.0 }	1 600 { 163.0 }	837 { 85.3 }
UP14M-HC	80	1 690 { 172.0 }	2 250 { 229.0 }	1 000 { 102.0 }
	100	2 170 { 221.0 }	2 880 { 294.0 }	1 260 { 128.0 }
	120	2 680 { 273.0 }	3 560 { 363.0 }	1 680 { 171.0 }

#### ■Axial load

The axial load is obtained by the following equation:

$$\text{Axial load} = 2T_i \times \sin \frac{\phi}{2}$$

T<sub>i</sub> : Installation tension N {kgf}

φ : Winding angle of small pulley degrees

### Adjustment of distance between two axes

In the transmission of only driving and driven pulleys, without using an idler, provide the adjusting margin (table below) of the distance between axes at the bearing including the manufacturing length (tolerance) of belt. In case of multi-axial transmission, make additional calculations for each belt span, and make conversion for the bi-axial transmission. Then obtain the adjusting margin.

#### ■Adjusting margin of inter-axial distance

		mm	
Type	Belt length	P2M·P3M·P5M UP3M·UP5M	P8M·P14M UP8M·UP14M
		ΔC <sub>o</sub>	Up to and incl. 500
ΔC <sub>o</sub>	500~1000	5	5
	1001~2000	10	10
	Over 2000	15	15
ΔC <sub>i</sub>	Common	10	15

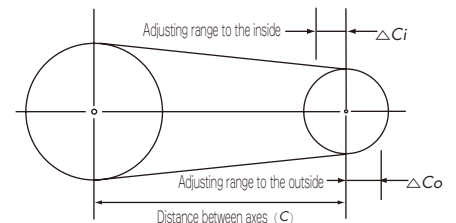



## DESIGN REFERENCE

### Alignment of pulley

Tsubaki synchronous belt does not turn at pulley center even when pulley-alignment is exact, and it is liable to deviate on either side. That force is very weak and when pulley alignment is poor, belt-side may be damaged. In extreme cases, it may run on the guide flange and break. Accordingly, adjust the alignment of pulley within the allowable range listed below.

#### Allowable range of pulley alignment

Belt Size	All			
Belt width mm	Up to and incl. 30	30~50	50~100	Over 100
Allowable degree of parallelization	Up to and incl. $\frac{5}{1000}$	Up to and incl. $\frac{4}{1000}$	Up to and incl. $\frac{3}{1000}$	Up to and incl. $\frac{2}{1000}$
$\theta$ min	Up to and incl. 17	Up to and incl. 13	Up to and incl. 10	Up to and incl. 6

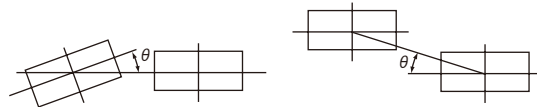

#### How to adjust the pulley:

As shown in the diagram, apply the straight edge to the end face of the pulley which is to be standard. Make the other pulley contact with straight edge on all faces (to make  $\epsilon = 0$ ). It is possible to take axial degree of parallelization simultaneously.

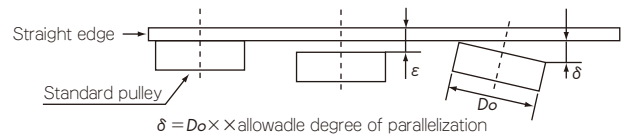

### Long belt

#### Connecting methods

##### Using belt clamp

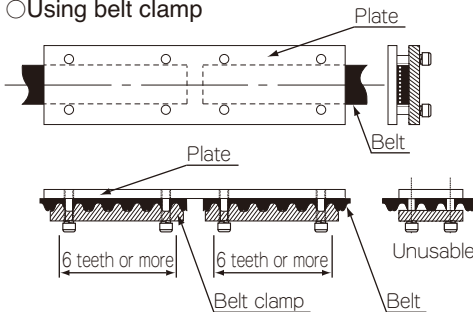

##### Using belt teeth

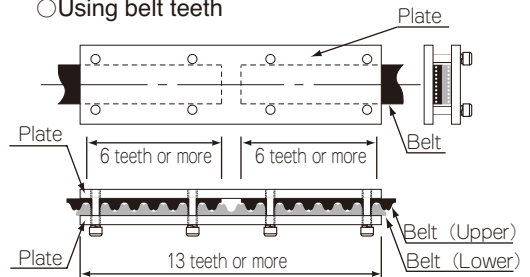

NOTE 1: The lower belt cutting piece must have 13 teeth or more. Glue the back side and plate.

NOTE 2: Do not make holes in the belt directly.

NOTE 3: Contact us for vertical driving.

NOTE 4: Chamfer the plate edge in contact with the belt.

### Belt dimensional tolerances

#### Belt length tolerance

PX Belt ULTRA PX Belt-HC	tolerance
up to and incl. 256	±0.41
Over 256, up to and incl. 384	±0.46
Over 384, up to and incl. 512	±0.51
Over 512, up to and incl. 760	±0.61
Over 760, up to and incl. 1016	±0.66
Over 1016, up to and incl. 1272	±0.76
Over 1272, up to and incl. 1528	±0.81
Over 1528, up to and incl. 1776	±0.86
Over 1776, up to and incl. 2032	±0.91
Over 2032, up to and incl. 2288	±0.97
Over 2288, up to and incl. 2544	±1.02
Over 2544, up to and incl. 2792	±1.07
Over 2792, up to and incl. 3048	±1.12
Over 3048, up to and incl. 3304	±1.17
Over 3304, up to and incl. 3560	±1.22
Over 3560, up to and incl. 3808	±1.26
Over 3808, up to and incl. 4064	±1.32
Over 4064, up to and incl. 4320	±1.37
Over 4320, up to and incl. 4576	±1.42

#### Belt width tolerance

##### PX/Ultra PX belt-HC

Belt width	Belt length		
	up to and incl. 840	Over 840, up to and incl. 1680	Over 1680
up to and incl. 10	+0.3 -0.6	+0.6 -0.6	-
Over 10, up to and incl. 45	+0.8 -0.8	+0.8 -1.2	+0.8 -1.2
Over 45, up to and incl. 75	+1.2 -1.6	+1.6 -1.6	+1.6 -1.6
Over 75, up to and incl. 100	+1.6 -1.6	+1.6 -2.0	+2.0 -2.0
Over 100	+2.4 -2.4	+2.4 -2.8	+2.4 -3.2



## P2M (P : 2 mm)

### ■ Pulley Type

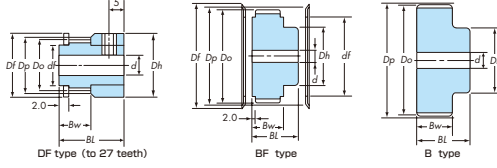

### ■ Tooth Shape

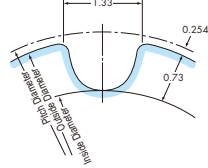

### ■ Materials

-Aluminum-  
High-strength aluminum

### ■ Model Identification

**PT 20 P 2M 6 DF**  
 Pulley No. of groove: PT  
 P: PX Size  
 Pulley type: DF  
 Belt width mm: 6

### ■ Model Identification (Flange)

**PT A S 10 170 100**  
 Pulley Material: PT  
 Shape: A  
 Thickness t: S (ex: 1.0 mm)  
 Outside diameter Df: 10 (ex: 17.0 mm)  
 Inside diameter df: 100 (ex: 10.0 mm)

Pulleys for models and materials not shown in the table below are also available (special models). Please contact us.

### ■ Pulley Types and Dimensions

No. of teeth <i>n</i>	Pitch diameter <i>D<sub>p</sub></i>	Outside diameter <i>D<sub>o</sub></i>	Hub diameter <i>D<sub>h</sub></i>	Bore size <i>d</i>		Flange Nominal <small>See the nominal examples for the dimensions.</small>	Models & materials (Bold letters show products in stock.)				
				Min	Max		P2M4	P2M6	P2M10		
											Aluminum
14	8.91	8.40	12	3	4	PTAS1012055	DF	<b>DF</b>	DF		
15	9.55	9.04	13		5	PTAS1013070	DF	<b>DF</b>	DF		
16	10.19	9.68					DF	<b>DF</b>	DF		
17	10.82	10.31	15		6	PTAS1015080	DF	<b>DF</b>	DF		
18	11.46	10.95					DF	<b>DF</b>	DF		
19	12.10	11.59	17		4	6.35	PTAS10170100	DF	DF	DF	
20	12.73	12.22		DF				<b>DF</b>	DF		
21	13.37	12.86		DF				<b>DF</b>	DF		
22	14.01	13.50		DF				<b>DF</b>	DF		
23	14.64	14.13		DF				<b>DF</b>	DF		
24	15.28	14.77		21				PTAS10210133	DF	<b>DF</b>	DF
25	15.92	15.41							DF	<b>DF</b>	DF
26	16.55	16.04		12				5	8	DF	<b>DF</b>
27	17.19	16.68	DF		<b>DF</b>	DF					
28	17.83	17.32	BF		<b>BF</b>	BF					
29	18.46	17.95	14		PTAF10260150	BF	<b>BF</b>			BF	
30	19.10	18.59				BF	<b>BF</b>			BF	
31	19.74	19.23	16		10	PTAF10280160	BF			<b>BF</b>	BF
32	20.37	19.86					BF			<b>BF</b>	BF
33	21.01	20.50	18		12	9	PTAF10290180			BF	<b>BF</b>
34	21.65	21.14		BF			<b>BF</b>	BF			
35	22.28	21.77		BF			<b>BF</b>	BF			
36	22.92	22.41		BF			<b>BF</b>	BF			
37	23.55	23.05		BF			<b>BF</b>	BF			
38	24.19	23.68		BF			<b>BF</b>	BF			
39	24.83	24.32		22			15	PTAF10340230	BF	<b>BF</b>	BF
40	25.46	24.96							BF	<b>BF</b>	BF
41	26.10	25.59	24	16	PTAF10320212	BF	<b>BF</b>	BF			
42	26.74	26.23				BF	<b>BF</b>	BF			
43	27.37	26.87	28	19	PTAF10360224	BF	<b>BF</b>	BF			
44	28.01	27.50				BF	<b>BF</b>	BF			
45	28.65	28.14	34	22	PTAF10390265	BF	<b>BF</b>	BF			
46	29.28	28.78				BF	<b>BF</b>	BF			
47	29.92	29.41	36	24	PTAF10430300	BF	<b>BF</b>	BF			
48	30.56	30.05				BF	<b>BF</b>	BF			
49	31.19	30.69	38	25	PTAF10450335	BF	<b>BF</b>	BF			
50	31.83	31.32				BF	<b>BF</b>	BF			
56	35.65	35.14	10	19	-	BF	<b>BF</b>	BF			
60	38.20	37.69				BF	<b>BF</b>	BF			
64	40.74	40.24	12	24	-	B	B	B			
72	45.84	45.33				B	B	B			
80	50.93	50.42	15	25	-	B	B	B			
84	53.48	52.97				B	B	B			
90	57.30	56.79	17	27	-	B	B	B			
96	61.12	60.61				B	B	B			
112	71.30	70.79	19	29	-	B	B	B			

No. of teeth	P2M4		P2M6		P2M10	
	Bw	BL	Bw	BL	Bw	BL
14 ~ 27	7	17	9.5	20	14	24
28 ~ 112	9	17	11.5	20	16	24

Belt Types and Dimensions P11,28

Selection and Design P39

- The minimum shaft hole diameters of in-stock products have been finished to the tolerances of 0 to 28 μ m.
- The BF type flanges of in-stock products are packaged separate from the bodies.
- The pulleys for the P2M6 can also be used for the P2M4 belts.



## P3M (P : 3 mm)

### ■ Pulley Type

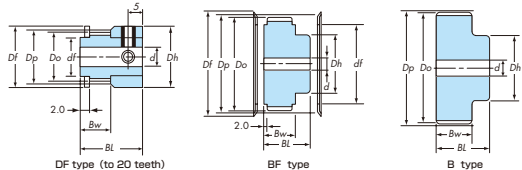

### ■ Tooth Shape

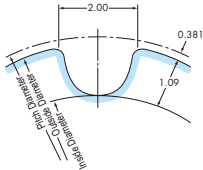

### ■ Materials

- Aluminum -  
High-strength aluminum
- Carbon steel -  
Carbon steel for machine structures

### ■ Model Identification

**PT 20 P 3M 10 BF-A**

- No. of groove: P: PX
- Size: 20
- Pulley type: P: 3M
- Hub diameter: 10
- Belt width mm: BF
- Materials: A: High-strength aluminum

### ■ Model Identification (Flange)

**PT S F 10 280 160**

- Pulley Material: S: SPCC, A: Aluminum
- Shape: F
- Hub diameter: 10
- Outside diameter Df: 280 (ex: 28.0 mm)
- Bore diameter d: 160 (ex: 16.0 mm)
- Thickness t: ex: 1.0 mm

Pulleys of models and materials not shown in the table below are also available (special models). Please contact us.

## ■ Pulley Types and Dimensions

No. of teeth n	Pitch diameter Dp	Outside diameter Do	Hub diameter Dh	Bore size d		Flange Nominal	Models & materials (Bold letters show products in stock.)							
				Min	Max		P3M6		P3M10		P3M15			
							See the nominal examples for the dimensions.			Carbon steel	Aluminum	Carbon steel	Aluminum	Carbon steel
10	9.55	8.79	12	4	4	PTSS1012055	DF		<b>DF</b>		<b>DF</b>			
11	10.50	9.74	13		5	PTAS1013070	DF		<b>DF</b>		<b>DF</b>			
12	11.46	10.70	15				DF		<b>DF</b>		<b>DF</b>			
13	12.41	11.65					DF		<b>DF</b>		<b>DF</b>			
14	13.37	12.61					DF		<b>DF</b>		<b>DF</b>			
15	14.32	13.56	17				DF		<b>DF</b>		<b>DF</b>			
16	15.28	14.52					DF		<b>DF</b>		<b>DF</b>			
17	16.23	15.47	21				DF		<b>DF</b>		<b>DF</b>			
18	17.19	16.43					DF		<b>DF</b>		<b>DF</b>			
19	18.14	17.38					DF		<b>DF</b>		<b>DF</b>			
20	19.10	18.34	25				DF		<b>DF</b>		<b>DF</b>			
21	20.05	19.29	12		5	8	PTSF10280160	BF	BF	<b>BF</b>	<b>BF</b>	<b>BF</b>	<b>BF</b>	
22	21.01	20.25						BF	BF	<b>BF</b>	<b>BF</b>	<b>BF</b>	<b>BF</b>	
23	21.96	21.20						BF	BF	<b>BF</b>	<b>BF</b>	<b>BF</b>	<b>BF</b>	
24	22.92	22.16	14			9	PTSF10290180	BF	BF	<b>BF</b>	<b>BF</b>	<b>BF</b>		
25	23.87	23.11					BF	BF	<b>BF</b>	<b>BF</b>	<b>BF</b>	<b>BF</b>		
26	24.83	24.07	16			10	PTSF10310190	BF	BF	<b>BF</b>	<b>BF</b>	<b>BF</b>		
27	25.78	25.02					BF	BF	<b>BF</b>	<b>BF</b>	<b>BF</b>	<b>BF</b>		
28	26.74	25.98					BF	BF	<b>BF</b>	<b>BF</b>	<b>BF</b>	<b>BF</b>		
29	27.69	26.93					BF	BF	<b>BF</b>	<b>BF</b>	<b>BF</b>	<b>BF</b>		
30	28.65	27.89	18			12	PTSF10340230	BF	BF	<b>BF</b>	<b>BF</b>	<b>BF</b>		
31	29.60	28.84				BF	BF	<b>BF</b>	<b>BF</b>	<b>BF</b>	<b>BF</b>			
32	30.56	29.80				BF	BF	<b>BF</b>	<b>BF</b>	<b>BF</b>	<b>BF</b>			
33	31.51	30.75	22	6	15	PTSF10390265	BF	BF	<b>BF</b>	<b>BF</b>	<b>BF</b>	<b>BF</b>		
34	32.47	31.71					BF	BF	<b>BF</b>	<b>BF</b>	<b>BF</b>	<b>BF</b>		
35	33.42	32.66	24			16	PTAF10430300	BF	BF	<b>BF</b>	<b>BF</b>	<b>BF</b>		
36	34.38	33.62					BF	BF	<b>BF</b>	<b>BF</b>	<b>BF</b>	<b>BF</b>		
37	35.33	34.57					BF	BF	<b>BF</b>	<b>BF</b>	<b>BF</b>	<b>BF</b>		
38	36.29	35.53	26				BF	BF	<b>BF</b>	<b>BF</b>	<b>BF</b>	<b>BF</b>		
39	37.24	36.48					BF	BF	<b>BF</b>	<b>BF</b>	<b>BF</b>	<b>BF</b>		
40	38.20	37.44	28		10	18	PTSF10450335	BF	BF	<b>BF</b>	<b>BF</b>	<b>BF</b>	<b>BF</b>	
41	39.15	38.39						BF	BF	<b>BF</b>	<b>BF</b>	<b>BF</b>	<b>BF</b>	
42	40.11	39.35						BF	BF	<b>BF</b>	<b>BF</b>	<b>BF</b>	<b>BF</b>	
43	41.06	40.30	32				20	PTSF10480375	BF	BF	<b>BF</b>	<b>BF</b>	<b>BF</b>	
44	42.02	41.25						BF	BF	<b>BF</b>	<b>BF</b>	<b>BF</b>	<b>BF</b>	
45	42.97	42.21	35			22	PTSF10520375	BF	BF	<b>BF</b>	<b>BF</b>	<b>BF</b>		
46	43.93	43.16				BF	BF	<b>BF</b>	<b>BF</b>	<b>BF</b>	<b>BF</b>			
47	44.88	44.12				BF	BF	<b>BF</b>	<b>BF</b>	<b>BF</b>	<b>BF</b>			
48	45.84	45.07	36	12	24	PTAF10520400	BF	BF	<b>BF</b>	<b>BF</b>	<b>BF</b>	<b>BF</b>		
49	46.79	46.03					BF	BF	<b>BF</b>	<b>BF</b>	<b>BF</b>	<b>BF</b>		
50	47.75	46.98					BF	BF	<b>BF</b>	<b>BF</b>	<b>BF</b>	<b>BF</b>		
56	53.48	52.71	40			26	PTSF10610490	BF	BF	<b>BF</b>	<b>BF</b>	<b>BF</b>		
60	57.30	56.53	46			31	PTAF10650530	BF	BF	<b>BF</b>	<b>BF</b>	<b>BF</b>		
64	61.12	60.35	48			32	PTSF10670560	BF	BF	<b>BF</b>	<b>BF</b>	<b>BF</b>		
72	68.75	67.99	50				BF	BF	<b>BF</b>	<b>BF</b>	<b>BF</b>	<b>BF</b>		
80	76.39	75.63	54		15	36	PTSF10820670	BF	BF	<b>BF</b>	<b>BF</b>	<b>BF</b>	<b>BF</b>	
84	80.21	79.45	60				40	PTSF10860710	BF	BF	<b>BF</b>	<b>BF</b>	<b>BF</b>	<b>BF</b>
90	85.94	85.18	65					-	B	B	B	B	B	B
96	91.67	90.91					-	B	B	B	B	B	B	
112	106.95	106.19	70			20		B	B	B	B	B	B	

No. of teeth	P3M6		P3M10		P3M15	
	Bw	BL	Bw	BL	Bw	BL
10 ~ 20	9.5	19	13	23	19	29
21 ~ 112	11.5	19	16	23	21	29

Belt Types and Dimensions P12,18,24,28

Selection and Design P39

- The prepared hole diameters of in-stock products have been finished to the minimum shaft diameters. (H9)
- The BF type flanges of in-stock products are packaged separate from the bodies.
- The flanges of in-stock products are made of SPCC if the pulleys are made of carbon steel or aluminum if the pulleys are made of aluminum. The dimensions and shapes are as shown in the above table.
- The pulleys for the P3M10 can also be used for the P3M6 belts.



## P5M (P : 5 mm)

### ■ Pulley Type

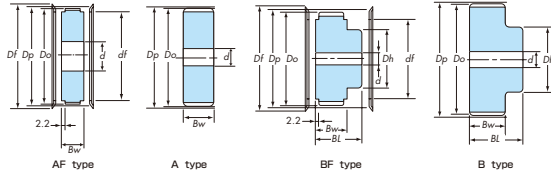

### ■ Tooth Shape

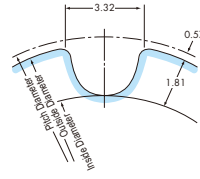

### ■ Materials

- Aluminum-
- Equivalent A7075
- Carbon steel-
- Carbon steel for machine structures

### ■ Model Identification

**PT 20 P 5M 25 BF-A**

No. of groove: Pulley  
P : PX  
Size: Belt width mm  
Pulley type: 25 BF-A  
Materials: A : Aluminum, blank : Carbon steel for machine structures

### ■ Model Identification (Flange)

**PT S F 10 430 300**

Pulley Material: S : SPCC, A : Aluminum  
Shape: Thickness  $t$  ex : 1.0 mm  
Inside diameter  $df$  ex : 30.0 mm  
Outside diameter  $Df$  ex : 43.0 mm

Pulleys of models and materials not shown in the table below are also available (special models). Please contact us.

## ■ Pulley Types and Dimensions

mm

No. of teeth $n$	Pitch diameter $D_p$	Outside diameter $D_o$	Hub diameter $D_h$	Bore size $d$		Flange Nominal See the nominal examples for the dimensions.	Models & materials (Bold letters show products in stock.)								
				Min	Max		P5M10		P5M15		P5M25				
							Carbon steel	Aluminum	Carbon steel	Aluminum	Carbon steel	Aluminum			
12	19.10	17.96	11	5	6	PTSF10230130	<b>AF·BF</b>	AF·BF	<b>AF·BF</b>	AF·BF	<b>AF·BF</b>	AF·BF	AF·BF		
13	20.69	19.55	12				PTSF10260150	AF·BF	AF·BF	AF·BF	AF·BF	AF·BF	AF·BF	AF·BF	
14	22.28	21.14	13				PTSF10280160	<b>AF·BF</b>	AF·BF	<b>AF·BF</b>	AF·BF	<b>AF·BF</b>	AF·BF	AF·BF	
15	23.87	22.73	15			8	PTSF10290180	AF·BF	AF·BF	AF·BF	AF·BF	AF·BF	AF·BF	AF·BF	
16	25.46	24.32	17			PTSF10310190	<b>AF·BF</b>	<b>AF·BF</b>	<b>AF·BF</b>	<b>AF·BF</b>	<b>AF·BF</b>	<b>AF·BF</b>	<b>AF·BF</b>		
17	27.06	25.91	18	6	10	PTSF10320212	AF·BF	AF·BF	AF·BF	AF·BF	AF·BF	AF·BF	AF·BF		
18	28.65	27.51	19		12	PTSF10360224	<b>AF·BF</b>	<b>AF·BF</b>	<b>AF·BF</b>	<b>AF·BF</b>	<b>AF·BF</b>	<b>AF·BF</b>	<b>AF·BF</b>		
19	30.24	29.10						AF·BF	AF·BF	AF·BF	AF·BF	AF·BF	AF·BF	AF·BF	
20	31.83	30.69					<b>AF·BF</b>	<b>AF·BF</b>	<b>AF·BF</b>	<b>AF·BF</b>	<b>AF·BF</b>	<b>AF·BF</b>	<b>AF·BF</b>		
21	33.42	32.28	23		14	PTSF10390265	AF·BF	AF·BF	AF·BF	AF·BF	AF·BF	AF·BF	AF·BF		
22	35.01	33.87	25	8	17	PTSF10430300	<b>AF·BF</b>	<b>AF·BF</b>	<b>AF·BF</b>	<b>AF·BF</b>	<b>AF·BF</b>	<b>AF·BF</b>	<b>AF·BF</b>		
23	36.61	35.46							AF·BF	AF·BF	AF·BF	AF·BF	AF·BF	AF·BF	AF·BF
24	38.20	37.06							PTSF10440310	<b>AF·BF</b>	<b>AF·BF</b>	<b>AF·BF</b>	<b>AF·BF</b>	<b>AF·BF</b>	<b>AF·BF</b>
25	39.79	38.65							PTSF10450335	<b>AF·BF</b>	<b>AF·BF</b>	<b>AF·BF</b>	<b>AF·BF</b>	<b>AF·BF</b>	<b>AF·BF</b>
26	41.38	40.24	30	10	20	PTSF10470355	<b>AF·BF</b>	<b>AF·BF</b>	<b>AF·BF</b>	<b>AF·BF</b>	<b>AF·BF</b>	<b>AF·BF</b>	<b>AF·BF</b>		
27	42.97	41.83							PTSF10480375	AF·BF	AF·BF	AF·BF	AF·BF	AF·BF	AF·BF
28	44.56	43.42						22	PTSF10520375	<b>AF·BF</b>	<b>AF·BF</b>	<b>AF·BF</b>	<b>AF·BF</b>	<b>AF·BF</b>	<b>AF·BF</b>
29	46.15	45.01							PTSF10520400	AF·BF	AF·BF	AF·BF	AF·BF	AF·BF	AF·BF
30	47.75	46.60	35	12	24	<b>AF·BF</b>	<b>AF·BF</b>	<b>AF·BF</b>	<b>AF·BF</b>	<b>AF·BF</b>	<b>AF·BF</b>	<b>AF·BF</b>	<b>AF·BF</b>		
31	49.34	48.20							PTSF10550425	AF·BF	AF·BF	AF·BF	AF·BF	AF·BF	AF·BF
32	50.93	49.79						26	PTSF10580450	<b>AF·BF</b>	<b>AF·BF</b>	<b>AF·BF</b>	<b>AF·BF</b>	<b>AF·BF</b>	<b>AF·BF</b>
33	52.52	51.38								AF·BF	AF·BF	AF·BF	AF·BF	AF·BF	AF·BF
34	54.11	52.97	42	12	28	PTSF10610490	AF·BF	AF·BF	AF·BF	AF·BF	AF·BF	AF·BF	AF·BF		
35	55.70	54.56							PTSF10640500	<b>AF·BF</b>	<b>AF·BF</b>	<b>AF·BF</b>	<b>AF·BF</b>	<b>AF·BF</b>	<b>AF·BF</b>
36	57.30	56.15						30	PTSF10650530	AF·BF	AF·BF	AF·BF	AF·BF	AF·BF	AF·BF
37	58.89	57.75								AF·BF	AF·BF	AF·BF	AF·BF	AF·BF	AF·BF
38	60.48	59.34	46	15	32	PTSF10670560	<b>AF·BF</b>	<b>AF·BF</b>	<b>AF·BF</b>	<b>AF·BF</b>	<b>AF·BF</b>	<b>AF·BF</b>	<b>AF·BF</b>		
39	62.07	60.93							PTSF10710600	AF·BF	AF·BF	AF·BF	AF·BF	AF·BF	AF·BF
40	63.66	62.52						35		AF·BF	AF·BF	AF·BF	AF·BF	AF·BF	AF·BF
41	65.25	64.11							PTSF10740630	<b>AF·BF</b>	<b>AF·BF</b>	<b>AF·BF</b>	<b>AF·BF</b>	<b>AF·BF</b>	<b>AF·BF</b>
42	66.85	65.70	52	15	38		AF·BF	AF·BF	AF·BF	AF·BF	AF·BF	AF·BF	AF·BF		
43	68.44	67.29							PTSF10820670	AF·BF	AF·BF	AF·BF	AF·BF	AF·BF	AF·BF
44	70.03	68.89								<b>AF·BF</b>	<b>AF·BF</b>	<b>AF·BF</b>	<b>AF·BF</b>	<b>AF·BF</b>	<b>AF·BF</b>
45	71.62	70.48							PTSF10860710	AF·BF	AF·BF	AF·BF	AF·BF	AF·BF	AF·BF
46	73.21	72.07	58	20	42		<b>AF·BF</b>	<b>AF·BF</b>	<b>AF·BF</b>	<b>AF·BF</b>	<b>AF·BF</b>	<b>AF·BF</b>	<b>AF·BF</b>		
47	74.80	73.66								AF·BF	AF·BF	AF·BF	AF·BF	AF·BF	AF·BF
48	76.39	75.25								<b>AF·BF</b>	<b>AF·BF</b>	<b>AF·BF</b>	<b>AF·BF</b>	<b>AF·BF</b>	<b>AF·BF</b>
49	77.99	76.84						46	-	AF·BF	AF·BF	AF·BF	AF·BF	AF·BF	AF·BF
50	79.58	78.44	64	20	46		<b>AF·BF</b>	<b>AF·BF</b>	<b>AF·BF</b>	<b>AF·BF</b>	<b>AF·BF</b>	<b>AF·BF</b>	<b>AF·BF</b>		
51	81.17	80.03								A·B	A·B	A·B	A·B	A·B	A·B
52	82.76	81.62						54	PTSF101030850	<b>AF·BF</b>	<b>AF·BF</b>	<b>AF·BF</b>	<b>AF·BF</b>	<b>AF·BF</b>	<b>AF·BF</b>
53	84.35	83.21								A·B	A·B	A·B	A·B	A·B	A·B
54	85.94	84.80	70	20	50		A·B	A·B	A·B	A·B	A·B	A·B	A·B		
55	87.53	86.39								A·B	A·B	A·B	A·B	A·B	A·B
56	89.13	87.98						56	-	A·B	A·B	A·B	A·B	A·B	A·B
57	90.72	89.58								A·B	A·B	A·B	A·B	A·B	A·B
58	92.31	91.17	76	20	54		A·B	A·B	A·B	A·B	A·B	A·B	A·B		
59	93.90	92.76								A·B	A·B	A·B	A·B	A·B	A·B
60	95.49	94.35						60	PTSF1012001060	<b>AF·BF</b>	AF·BF	<b>AF·BF</b>	AF·BF	<b>AF·BF</b>	AF·BF
61	97.08	95.94								A·B	A·B	A·B	A·B	A·B	A·B
62	98.67	97.53	82	20	58		A·B	A·B	A·B	A·B	A·B	A·B	A·B		
63	100.26	99.12								A·B	A·B	A·B	A·B	A·B	A·B
64	101.85	100.72								A·B	A·B	A·B	A·B	A·B	A·B
65	103.44	102.30						65	-	A·B	A·B	A·B	A·B	A·B	A·B
66	105.03	103.89	88	20	60		A·B	A·B	A·B	A·B	A·B	A·B	A·B		
67	106.62	105.48								A·B	A·B	A·B	A·B	A·B	A·B
68	108.21	107.07								A·B	A·B	A·B	A·B	A·B	A·B
69	109.80	108.66						70	-	A·B	A·B	A·B	A·B	A·B	A·B
70	111.39	110.25	94	20	62		A·B	A·B	A·B	A·B	A·B	A·B	A·B		
71	112.98	111.84								A·B	A·B	A·B	A·B	A·B	A·B
72	114.57	113.43								A·B	A·B	A·B	A·B	A·B	A·B
73	116.16	115.02						75	-	A·B	A·B	A·B	A·B	A·B	A·B
74	117.75	116.61	100	20	64		A·B	A·B	A·B	A·B	A·B	A·B	A·B		
75	119.34	118.20								A·B	A·B	A·B	A·B	A·B	A·B
76	120.93	119.79								A·B	A·B	A·B	A·B	A·B	A·B
77	122.52	121.38						80	-	A·B	A·B	A·B	A·B	A·B	A·B
78	124.11	122.97	106	20	66		A·B	A·B	A·B	A·B	A·B	A·B	A·B		
79	125.70	124.56								A·B	A·B	A·B	A·B	A·B	A·B
80	127.29	126.15								A·B	A·B	A·B	A·B	A·B	A·B
81	128.88	127.01						75	-	A·B	A·B	A·B	A·B	A·B	A·B
82	130.47	128.60	112	20	68		A·B	A·B	A·B	A·B	A·B	A·B	A·B		
83	132.06	129.19								A·B	A·B	A·B	A·B	A·B	A·B
84	133.65	130.78								A·B	A·B	A·B	A·B	A·B	A·B
85	135.24	132.37						80	-	A·B	A·B	A·B	A·B	A·B	A·B

No. of teeth	P5M10		P5M15		P5M25	
	Bw	BL	Bw	BL	Bw	BL
12 ~ 112	16	28	21	33	32	44

Hand icon: Belt Types and Dimensions P13,16,19,22,25,28

Hand icon: Selection and Design P39

- The diameter of the prepared hole is "minimum bore - 1 mm."
- The flanges of in-stock products are packaged separate from the bodies.
- The flanges of in-stock products are made of SPCC if the pulleys are made of carbon steel or aluminum if the pulleys are made of aluminum. The dimensions and shapes are as shown in the above table.



## P8M (P : 8 mm)

### Pulley Type

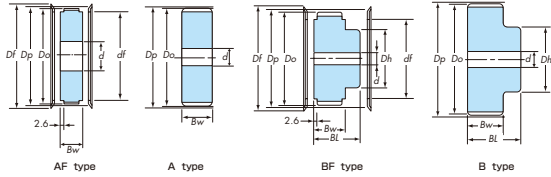

### Tooth Shape

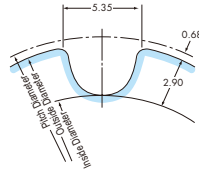

### Materials

- Aluminum-  
Equivalent A7075
- Carbon steel-  
Carbon steel for machine structures

### Model Identification

**PT 20 P 8M 25 BF-A**

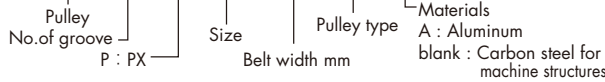

### Model Identification (Flange)

**PT S F 16 550 425**

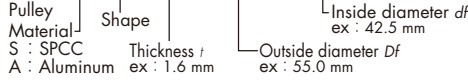

Pulleys of models and materials not shown in the table below are also available (special models). Please contact us.

## Pulley Types and Dimensions

No. of teeth <i>n</i>	Pitch diameter <i>Dp</i>	Outside diameter <i>Do</i>	Hub diameter <i>Dh</i>	Bore size <i>d</i>		Flange Nominal <small>See the nominal examples for the dimensions.</small>	Models & materials (Bold letters show products in stock.)							
				Min	Max		P8M15		P8M25		P8M40		P8M60	
						Carbon steel	Aluminum	Carbon steel	Aluminum	Carbon steel	Aluminum	Carbon steel	Aluminum	
20	50.93	49.56	36	22	23	PTSF16550425	<b>AF·BF</b>	<b>AF·BF</b>	<b>AF·BF</b>	<b>AF·BF</b>	<b>AF·BF</b>	<b>AF·BF</b>	<b>AF·BF</b>	<b>AF·BF</b>
21	53.48	52.10	39	23	25	PTSF16610450	AF·BF	AF·BF	AF·BF	AF·BF	AF·BF	AF·BF	AF·BF	AF·BF
22	56.02	54.65	41	25	26	PTSF16620450	<b>AF·BF</b>	<b>AF·BF</b>	<b>AF·BF</b>	<b>AF·BF</b>	<b>AF·BF</b>	<b>AF·BF</b>	<b>AF·BF</b>	<b>AF·BF</b>
23	58.57	57.20	43	26	28	PTSF16660500	AF·BF	AF·BF	AF·BF	AF·BF	AF·BF	AF·BF	AF·BF	AF·BF
24	61.12	59.74	46	28	28	PTSF16700560	<b>AF·BF</b>	<b>AF·BF</b>	<b>AF·BF</b>	<b>AF·BF</b>	<b>AF·BF</b>	<b>AF·BF</b>	<b>AF·BF</b>	<b>AF·BF</b>
25	63.66	62.29	49	28	30	PTSF16730560	AF·BF	AF·BF	AF·BF	AF·BF	AF·BF	AF·BF	AF·BF	AF·BF
26	66.21	64.84	51	30	32	PTSF16790630	<b>AF·BF</b>	<b>AF·BF</b>	<b>AF·BF</b>	<b>AF·BF</b>	<b>AF·BF</b>	<b>AF·BF</b>	<b>AF·BF</b>	<b>AF·BF</b>
27	68.75	67.38	53	32	34	PTSF16820670	AF·BF	AF·BF	AF·BF	AF·BF	AF·BF	AF·BF	AF·BF	AF·BF
28	71.30	69.93	55	34	36	PTSF16860710	<b>AF·BF</b>	<b>AF·BF</b>	<b>AF·BF</b>	<b>AF·BF</b>	<b>AF·BF</b>	<b>AF·BF</b>	<b>AF·BF</b>	<b>AF·BF</b>
29	73.85	72.48	58	36	38	PTSF16910770	AF·BF	AF·BF	AF·BF	AF·BF	AF·BF	AF·BF	AF·BF	AF·BF
30	76.39	75.02	60	38	40	PTSF16940770	<b>AF·BF</b>	<b>AF·BF</b>	<b>AF·BF</b>	<b>AF·BF</b>	<b>AF·BF</b>	<b>AF·BF</b>	<b>AF·BF</b>	<b>AF·BF</b>
31	78.94	77.57	63	40	42	PTSF16970800	AF·BF	AF·BF	AF·BF	AF·BF	AF·BF	AF·BF	AF·BF	AF·BF
32	81.49	80.12	65	42	44	PTSF161030850	<b>AF·BF</b>	<b>AF·BF</b>	<b>AF·BF</b>	<b>AF·BF</b>	<b>AF·BF</b>	<b>AF·BF</b>	<b>AF·BF</b>	<b>AF·BF</b>
33	84.03	82.66	67	44	46	PTSF161070900	AF·BF	AF·BF	AF·BF	AF·BF	AF·BF	AF·BF	AF·BF	AF·BF
34	86.58	85.21	70	46	48	PTSF161110950	<b>AF·BF</b>	<b>AF·BF</b>	<b>AF·BF</b>	<b>AF·BF</b>	<b>AF·BF</b>	<b>AF·BF</b>	<b>AF·BF</b>	<b>AF·BF</b>
35	89.13	87.75	73	48	50	PTSF1611501020	AF·BF	AF·BF	AF·BF	AF·BF	AF·BF	AF·BF	AF·BF	AF·BF
36	91.67	90.30	75	50	52	PTSF1611901020	<b>AF·BF</b>	<b>AF·BF</b>	<b>AF·BF</b>	<b>AF·BF</b>	<b>AF·BF</b>	<b>AF·BF</b>	<b>AF·BF</b>	<b>AF·BF</b>
37	94.22	92.85	77	52	54	PTSF1612701200	AF·BF	AF·BF	AF·BF	AF·BF	AF·BF	AF·BF	AF·BF	AF·BF
38	96.77	95.39	80	54	56	PTSF1613501150	<b>AF·BF</b>	<b>AF·BF</b>	<b>AF·BF</b>	<b>AF·BF</b>	<b>AF·BF</b>	<b>AF·BF</b>	<b>AF·BF</b>	<b>AF·BF</b>
39	99.31	97.94	83	56	58	PTSF1613501200	AF·BF	AF·BF	AF·BF	AF·BF	AF·BF	AF·BF	AF·BF	AF·BF
40	101.86	100.49	85	58	60	PTSF1615801400	<b>AF·BF</b>	<b>AF·BF</b>	<b>AF·BF</b>	<b>AF·BF</b>	<b>AF·BF</b>	<b>AF·BF</b>	<b>AF·BF</b>	<b>AF·BF</b>
41	104.41	103.03	86	60	62	PTSF1616701520	AF·BF	AF·BF	AF·BF	AF·BF	AF·BF	AF·BF	AF·BF	AF·BF
42	106.95	105.58	87	62	64	PTSF1619001700	<b>AF·BF</b>	<b>AF·BF</b>	<b>AF·BF</b>	<b>AF·BF</b>	<b>AF·BF</b>	<b>AF·BF</b>	<b>AF·BF</b>	<b>AF·BF</b>
43	109.50	108.13	88	64	65	-	A·B	A·B	A·B	A·B	A·B	A·B	A·B	A·B
44	112.05	110.67	90	65	70	-	A·B	A·B	A·B	A·B	A·B	A·B	A·B	A·B
45	114.59	113.22	92	70	75	-	A·B	A·B	A·B	A·B	A·B	A·B	A·B	A·B
46	117.14	115.77	95	75	-	-	A·B	A·B	A·B	A·B	A·B	A·B	A·B	A·B
47	119.68	118.31	98	-	-	-	A·B	A·B	A·B	A·B	A·B	A·B	A·B	A·B
48	122.23	120.86	100	62	-	-	A·B	A·B	A·B	A·B	A·B	A·B	A·B	A·B
49	124.78	123.41	100	64	-	-	A·B	A·B	A·B	A·B	A·B	A·B	A·B	A·B
50	127.32	125.95	100	66	-	-	A·B	A·B	A·B	A·B	A·B	A·B	A·B	A·B
56	142.60	141.23	110	65	-	-	A·B	A·B	A·B	A·B	A·B	A·B	A·B	A·B
60	152.79	151.42	110	65	-	-	A·B	A·B	A·B	A·B	A·B	A·B	A·B	A·B
64	162.97	161.60	110	65	-	-	A·B	A·B	A·B	A·B	A·B	A·B	A·B	A·B
72	183.35	181.97	110	65	-	-	A·B	A·B	A·B	A·B	A·B	A·B	A·B	A·B
80	203.72	202.35	120	65	-	-	A·B	A·B	A·B	A·B	A·B	A·B	A·B	A·B
84	213.90	212.53	126	70	-	-	A·B	A·B	A·B	A·B	A·B	A·B	A·B	A·B
90	229.18	227.81	130	75	-	-	A·B	A·B	A·B	A·B	A·B	A·B	A·B	A·B
96	244.46	243.09	130	-	-	-	A·B	A·B	A·B	A·B	A·B	A·B	A·B	A·B
112	285.21	283.83	144	80	-	-	A·B	A·B	A·B	A·B	A·B	A·B	A·B	A·B
120	305.58	304.21	144	80	-	-	A·B	A·B	A·B	A·B	A·B	A·B	A·B	A·B

No. of teeth	P8M15		P8M25		P8M40		P8M60	
	Bw	BL	Bw	BL	Bw	BL	Bw	BL
20 ~ 41	22	39	33	50	49	66	70	87
42 ~ 120	22	44	33	55	49	71	70	92

Belt Types and Dimensions P14,17,20,23,26,28

Selection and Design P39

- The diameter of the prepared hole is "minimum bore - 1 mm."
- The flanges of in-stock products are packaged separate from the bodies.
- The flanges of in-stock products are made of SPCC if the pulleys are made of carbon steel or aluminum if the pulleys are made of aluminum. The dimensions and shapes are as shown in the above table.



## P14M (P : 14 mm)

### Pulley Type

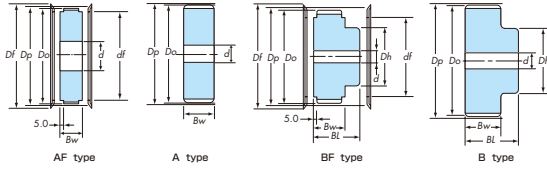

### Tooth Shape

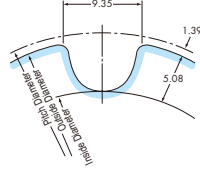

### Materials

-Carbon steel-  
Carbon steel for machine structures

### Model Identification

**PT 30 P 14M 40 BF**

Pulley  
No. of groove P : PX  
Size  
Belt width mm

### Flange

Lathe turning

Pulleys of models and materials not shown in the table below are also available (special models). Please contact us.

### Pulley Types and Dimensions

No. of teeth <i>n</i>	Pitch diameter <i>D<sub>p</sub></i>	Outside diameter <i>D<sub>o</sub></i>	Hub diameter <i>D<sub>h</sub></i>	Bore size <i>d</i>		Flange		Models & materials (Bold letters show products in stock.)				
				Min	Max	Outside <i>D<sub>f</sub></i>	Inside <i>d<sub>f</sub></i>	P14M40	P14M60	P14M80	P14M100	P14M120
								Carbon steel	Carbon steel	Carbon steel	Carbon steel	Carbon steel
28	124.78	121.98	90	56	136	102	<b>AF·BF</b>	<b>AF·BF</b>	AF·BF	AF·BF	AF·BF	
29	129.23	126.44	95	60	-	-	AF·BF	AF·BF	AF·BF	AF·BF	AF·BF	
30	133.69	130.90	100	62	145	111	<b>AF·BF</b>	<b>AF·BF</b>	AF·BF	AF·BF	AF·BF	
31	138.15	135.35	105	-	-	-	AF·BF	AF·BF	AF·BF	AF·BF	AF·BF	
32	142.60	139.81	110	62	154	120	<b>AF·BF</b>	<b>AF·BF</b>	AF·BF	AF·BF	AF·BF	
33	147.06	144.27	120	70	-	-	AF·BF	AF·BF	AF·BF	AF·BF	AF·BF	
34	151.52	148.72			163	129	<b>AF·BF</b>	<b>AF·BF</b>	AF·BF	AF·BF	AF·BF	
35	155.97	153.18			-	-	AF·BF	AF·BF	AF·BF	AF·BF	AF·BF	
36	160.43	157.63			171	137	<b>AF·BF</b>	<b>AF·BF</b>	AF·BF	AF·BF	AF·BF	
37	164.88	162.09	130	75	-	-	AF·BF	AF·BF	AF·BF	AF·BF		
38	169.34	166.55	181		146	<b>AF·BF</b>	<b>AF·BF</b>	AF·BF	AF·BF	AF·BF		
39	173.80	171.00	-		-	AF·BF	AF·BF	AF·BF	AF·BF	AF·BF		
40	178.25	175.46	190		155	<b>AF·BF</b>	<b>AF·BF</b>	AF·BF	AF·BF	AF·BF		
41	182.71	179.92	135	80	-	-	AF·BF	AF·BF	AF·BF	AF·BF		
42	187.17	184.37			198	164	<b>AF·BF</b>	<b>AF·BF</b>	AF·BF	AF·BF	AF·BF	
43	191.62	188.83			-	-	AF·BF	AF·BF	AF·BF	AF·BF	AF·BF	
44	196.08	193.28			207	173	<b>AF·BF</b>	<b>AF·BF</b>	AF·BF	AF·BF	AF·BF	
45	200.54	197.74	155	85	-	-	AF·BF	AF·BF	AF·BF	AF·BF		
46	204.99	202.20	-		-	AF·BF	AF·BF	AF·BF	AF·BF	AF·BF		
47	209.45	206.65	-		-	AF·BF	AF·BF	AF·BF	AF·BF	AF·BF		
48	213.90	211.11	225		191	<b>AF·BF</b>	<b>AF·BF</b>	AF·BF	AF·BF	AF·BF		
49	218.36	215.57	160	90	-	-	AF·BF	AF·BF	AF·BF	AF·BF		
50	222.82	220.02			234	200	<b>AF·BF</b>	<b>AF·BF</b>	AF·BF	AF·BF	AF·BF	
56	249.55	246.76			-	-	A·B	A·B	A·B	A·B	A·B	
60	267.38	264.59			-	-	A·B	A·B	A·B	A·B	A·B	
64	285.21	282.41	170	35	-	-	A·B	A·B	A·B	A·B		
72	320.86	318.07			-	-	A·B	A·B	A·B	A·B	A·B	
80	356.51	353.71			100	-	A·B	A·B	A·B	A·B	A·B	
84	374.33	371.54			110	-	A·B	A·B	A·B	A·B	A·B	
90	401.07	398.28	180	40	120	-	A·B	A·B	A·B			
96	427.81	425.01	200	40	-	-	A·B	A·B	A·B	A·B		
112	499.11	496.32	240		150	-	-	A·B	A·B	A·B		
120	534.76	531.97	250		-	-	-	A·B	A·B	A·B		
			300		180	-	-	A·B	A·B	A·B		

No. of teeth	P14M40		P14M60		P14M80		P14M100		P14M120	
	Bw	BL	Bw	BL	Bw	BL	Bw	BL	Bw	BL
28 ~ 43	53	73	74	94	95	115	116	136	137	157
44 ~ 120	53	78	74	99	95	120	116	141	137	162

Belt Types and Dimensions	P15,21
Selection and Design	P39

- The diameter of the prepared hole is "minimum bore - 1 mm."
- The flanges of in-stock products are packaged separate from the bodies.





## CYLINDRICAL PULLEY (PX)

### Size

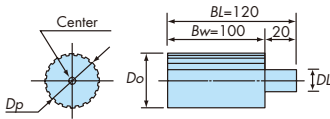

### Processing shape ( Reference )

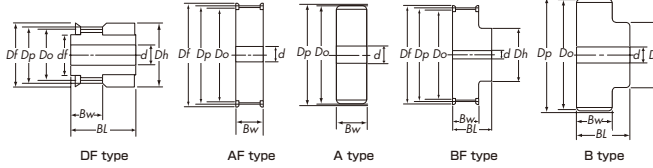

### Model Identification

**PT 20 P 2M-100L-S**

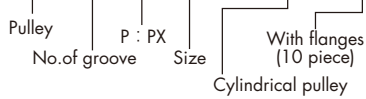

### Model Identification (Flange)

**PT A F 10 360 224**

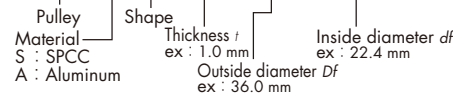

### Materials

High-strength aluminum

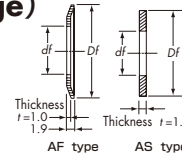

### Pulley Types and Dimensions (P2M)

No. of teeth <i>n</i>	Pitch diameter <i>D<sub>p</sub></i>	Outside diameter <i>D<sub>o</sub></i>	Hub diameter <i>D<sub>L</sub></i>	Flange	
				Nominal <small>See the nominal examples for the dimensions.</small>	
10	6.37	5.86	4	PTAS1011040	
11	7.00	6.49		PTAS1012055	
12	7.64	7.13			
13	8.28	7.77			
14	8.91	8.40	6		PTAS1013070
15	9.55	9.04		PTAS1015080	
16	10.19	9.68			
17	10.82	10.31			
18	11.46	10.95	8		PTAS10170100
19	12.10	11.59		PTAS10170100	
20	12.73	12.22			
21	13.37	12.86			
22	14.01	13.50	10		PTAS10250150
23	14.64	14.13		PTAF10260150	
24	15.28	14.77			PTAF10280160
25	15.92	15.41			
26	16.55	16.04	PTAF10320212		
27	17.19	16.68		PTAF10340230	
28	17.83	17.32			PTAF10360224
30	19.10	18.59			
32	20.37	19.86	PTAF10450335		
36	22.92	22.41		PTAF10450335	
40	25.46	24.96			PTAF10450335
44	28.01	27.50			
48	30.56	30.05	PTAF10450335		
50	31.83	31.32		PTAF10450335	
60	38.20	37.69			PTAF10450335

### Pulley Types and Dimensions (P3M)

No. of teeth <i>n</i>	Pitch diameter <i>D<sub>p</sub></i>	Outside diameter <i>D<sub>o</sub></i>	Hub diameter <i>D<sub>L</sub></i>	Flange
				Nominal <small>See the nominal examples for the dimensions.</small>
10	9.55	8.79	4	PTAS1012055
11	10.50	9.74		PTAS1013070
12	11.46	10.70	6	
13	12.41	11.65		
14	13.37	12.61	8	PTAS10170100
15	14.32	13.56		
16	15.28	14.52	12	PTAS10250150
18	17.19	16.43		
19	18.14	17.38	PTAF10290180	
20	19.10	18.34		PTAF10310190
21	20.05	19.29	PTAF10320212	
22	21.01	20.25		PTAF10340230
24	22.92	22.16	PTAF10360224	
25	23.87	23.11		PTAF10430300
26	24.83	24.07	PTAF10450335	
28	26.74	25.98		PTAF10520400
30	28.65	27.89	PTAF10550425	
32	30.56	29.80		PTAF10650530
36	34.38	33.62	PTAF10650530	
40	38.20	37.44		PTAF10650530
48	45.84	45.07	PTAF10650530	
50	47.75	46.98		PTAF10650530
60	57.30	56.53	PTAF10650530	

Belt Types and Dimensions P1,12,18,24,28

Selection and Design P39



## CYLINDRICAL PULLEY (PX)

### Size

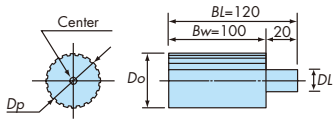

### Processing shape ( Reference )

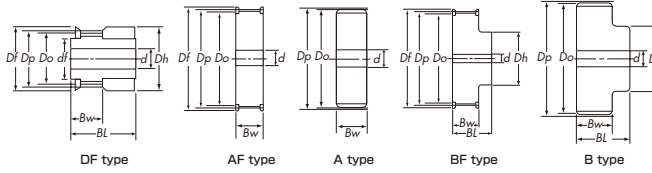

### Model Identification

**PT 20 P 5M-100L-S**

Pulley  
No. of groove  
P : PX  
Size  
With flanges  
(10 piece)  
Cylindrical pulley

### Model Identification (Flange)

**PT A F 10 640 500**

Pulley  
Material  
A : Aluminum  
Shape  
Thickness  $t$   
ex : 1.0 mm  
Inside diameter  
ex : 50.0 mm  
Outside diameter  $D_f$   
ex : 64.0 mm

### Materials

High-strength aluminum

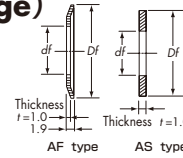

### Pulley Types and Dimensions (P5M)

No. of teeth $n$	Pitch diameter $D_p$	Outside diameter $D_o$	Hub diameter $D_L$	Flange Nominal <small>See the nominal examples for the dimensions.</small>	
12	19.10	17.96	12	PTAF10230130	
14	22.28	21.14		PTAF10280160	
15	23.87	22.73		PTAF10290180	
16	25.46	24.32		PTAF10310190	
17	27.06	25.91		PTAF10320212	
18	28.65	27.51		16	PTAF10360224
19	30.24	29.10			PTAF10390265
20	31.83	30.69			
21	33.42	32.28			PTAF10430300
22	35.01	33.87			PTAF10440310
24	38.20	37.06			PTAF10450335
25	39.79	38.65			PTAF10470355
26	41.38	40.24			PTAF10520375
28	44.56	43.42			PTAF10550425
30	47.75	46.60			
32	50.93	49.79		16	PTAF10640500
36	57.30	56.15			PTAF10670560
40	63.66	62.52	PTAF10740630		
44	70.03	68.89	PTAF10820670		
48	76.39	75.25	PTAF10860710		
50	79.58	78.44	PTAF101030850		
60	95.49	94.35			

Belt Types and Dimensions P13,16,19,22,25,28

Selection and Design P39

# TSUBAKI Lock Pulleys

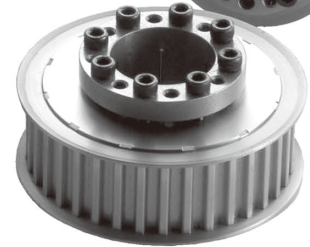

## Type S (Aluminum pulleys)

- Aluminum types of type S pulleys
- Light weight and light inertia

## Type S

- Most standard type
- Substantial for middle and large sizes

## Selectable & Usable Lock Pulleys

Four types of Tsubaki Lock Pulleys are available according to applications.  
Suitable to all needs.

### Features

- Friction coupling eliminates loose coupling.
- Easy phase adjustment, mounting and dismounting.
- Requires no stopper in the axial direction.
- Easy type selection requiring no calculations.
- Requires model types when placing orders. Requires no additional machining.
- Easy fixing with few bolts.

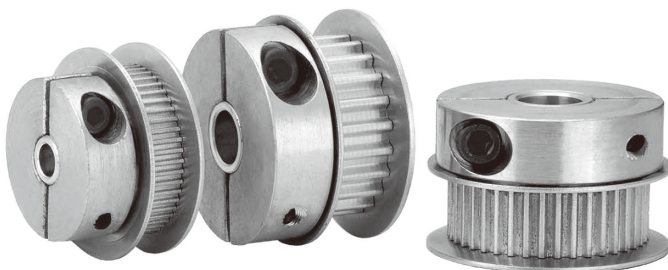

## Type C

- New type with clamp collars
- External tightening for application to small-diameter shafts

Refer to the separate catalog for details.

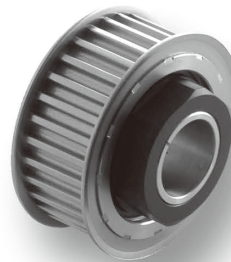

## Type N

- Requires tightening of a single nut.
- Enables easy clamping.

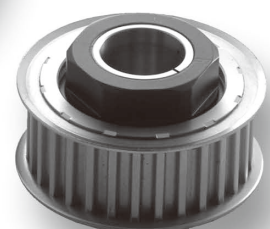



## DESIGN REFERENCE

### Pulley materials

The following materials are suitable for pulleys:

Materials	Code
Carbon steel for machine structural use	S15C~S55C
High tensile aluminum alloy	A2017-T4
Gray cast iron	FC200~FC300
Stainless steel	SUS303

### General equations for pulley calculation

• **Pitch diameter**  $D_p = \frac{N \times p}{\pi}$

• **Outside diameter**  $D_o = D_p - 2a = \frac{N \times p}{\pi} - 2a$

$p$  : Belt pitch mm  
 $N$  : Number of teeth of pulley  
 $a$  : Pitch line depth (PLD) mm

	P3M	P5M	P8M	P14M
Pitch	3.00	5.00	8.00	14.00
a (PLD)	0.381	0.571	0.686	1.397

### Tolerances of pulley dimensions

#### Errors in tooth trace direction (relative to finished bore centerline)

Parallelism between tooth and bore centerline mm

Belt Width	Tolerance of Error in Tooth Trace Direction
Up to and incl. 50	0.03
Over 50, up to and incl. 100	0.04
Over 100	0.05

#### Runout of addendum circle (relative to finished bore centerline)

mm

Addendum Circle Dia	Allowable Runout
Up to and incl. 203.20	0.13
Over 203.20	$0.13 + [(Outside\ diameter - 203.20) \times 0.0005]$

#### Runout of side face (relative to finished bore centerline)

mm

Addendum Circle Dia	Allowable Runout
Up to and incl. 101.60	0.10
Over 101.60, up to and incl. 254.00	$Outside\ diameter \times 0.001$
Over 254.00	$0.25 + [(Outside\ diameter - 254.00) \times 0.0005]$

#### Cylindricity of tip cylinder (Gradient = taper x 1/2)

mm

	Allowance
Up to and incl. 20	0.01
Over 20, up to and incl. 50	0.02
Over 50, up to and incl. 100	0.04
Over 100	0.06

- The tolerances shown in the left-side table are applicable to machined pulleys. For plastic pulleys, please contact us because they differ depending on the conditions of use and layout.
- For tolerances of the addendum circle diameter, please contact us.



## DESIGN REFERENCE

### Pulley width

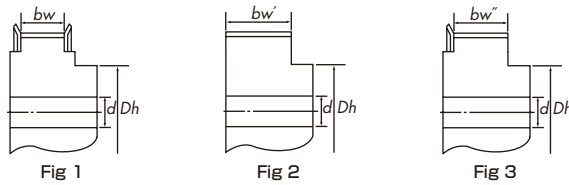

### ■ Belt width and Pulley width

mm

Type (Pitch)	Belt width	Pulley width (Standard)		
		Fig1 <i>bw</i>	Fig2 <i>bw'</i>	Fig3 <i>bw''</i>
<b>P2M</b>	4	5.0	9.0	7.0
	6	7.5	11.5	9.5
	10	12.0	16.0	14.0
<b>P3M</b>	6	7.5	11.5	9.5
	10	12.0	16.0	14.0
	15	17.0	21.0	19.0
<b>P5M</b>	10	11.6	16.0	13.8
	15	16.6	21.0	18.8
	25	27.6	32.0	29.8
<b>P8M</b>	15	16.8	22.0	19.4
	25	27.8	33.0	30.4
	40	43.8	49.0	46.4
	60	64.8	70.0	67.4
<b>P14M</b>	40	43.0	53.0	48.0
	60	64.0	74.0	69.0
	80	85.0	95.0	90.0
	100	106.0	116.0	111.0
	120	127.0	137.0	132.0

### Surface treatment

Various surface treatments are available according to applications.

Type of Surface Treatment	Effect	Applicable Material
Electro galvanizing	Rust prevention, decoration	Carbon steel
Blackening	Rust prevention, decoration	Carbon steel
Alumite	Rust prevention	Aluminum alloy
Hard alumite	Rust prevention, wear resistance	Aluminum alloy
Electroless nickel plating	Rust prevention, decoration	Carbon steel

### Special tooth Shape

For timing belt engagement, a backlash is usually provided. However, for timing belt drive used for robots, electronic component assembling machines, NC machines, printers, plotters, etc. that require highly accurate rotation, pulleys having a special backlash-less tooth profile with minimal backlash to minimize rotating angle errors are also available. Please contact us.



## DESIGN REFERENCE

### Coupling the pulley and shaft

(1) By use of key

A general method to secure the pulley based on the following bore-shaft fitting dimensional tolerances and keyway tolerances.

(2) By use of frictional force

A method to secure the pulley by use of a taper ring. A merit is that there is no looseness after securing. Tsubakimoto offers lock pulleys that utilize the frictional coupling system. When you want to study such pulleys, please contact us.

### ■ Bore and shaft fitting dimensional tolerances (JIS B0401)

Dimension Range mm	Bore Dimensional Tolerance		Shaft Dimensional Tolerance	
	H7	H8	h7	h8
Over 3, up to and incl. 6	+12~0	+18~0	0~-12	0~-18
Over 6, up to and incl. 10	+15~0	+22~0	0~-15	0~-22
Over 10, up to and incl. 18	+18~0	+27~0	0~-18	0~-27
Over 18, up to and incl. 30	+21~0	+33~0	0~-21	0~-33
Over 30, up to and incl. 50	+25~0	+39~0	0~-25	0~-39
Over 50, up to and incl. 80	+30~0	+46~0	0~-30	0~-46
Over 80, up to and incl. 120	+35~0	+54~0	0~-35	0~-54

### ● New JIS keys Js9 (Part name designation: J)

Bore Dia	Key	Keyway Height $d+h$	Keyway Dimensional Tolerance $bk$
Over 6, up to and incl. 8	2 × 2	$d+1.0$	$2\pm 0.0125$
Over 8, up to and incl. 10	3 × 3	$d+1.4$	$3\pm 0.0125$
Over 10, up to and incl. 12	4 × 4	$d+1.8$	$4\pm 0.0150$
Over 12, up to and incl. 17	5 × 5	$d+2.3$	$5\pm 0.0150$
Over 17, up to and incl. 22	6 × 6	$d+2.8$	$6\pm 0.0150$
Over 22, up to and incl. 30	8 × 7	$d+3.3$	$8\pm 0.0180$
Over 30, up to and incl. 38	10 × 8	$d+3.3$	$10\pm 0.0180$
Over 38, up to and incl. 44	12 × 8	$d+3.3$	$12\pm 0.0215$
Over 44, up to and incl. 50	14 × 9	$d+3.8$	$14\pm 0.0215$
Over 50, up to and incl. 58	16 × 10	$d+4.3$	$16\pm 0.0215$
Over 58, up to and incl. 65	18 × 11	$d+4.4$	$18\pm 0.0215$
Over 65, up to and incl. 75	20 × 12	$d+4.9$	$20\pm 0.0260$
Over 75, up to and incl. 85	22 × 14	$d+5.4$	$22\pm 0.0260$
Over 85, up to and incl. 95	25 × 14	$d+5.4$	$25\pm 0.0260$

### ● Old JIS keys E9 (Part name designation: E)

Bore Dia	Key	Keyway Height $d+h$	Keyway Dimensional Tolerance $bk$
Over 10, up to and incl. 13	4 × 4	$d+1.5$	$4\begin{matrix} +0.050 \\ +0.020 \end{matrix}$
Over 13, up to and incl. 20	5 × 5	$d+2.0$	$5\begin{matrix} +0.050 \\ +0.020 \end{matrix}$
Over 20, up to and incl. 30	7 × 7	$d+3.0$	$7\begin{matrix} +0.061 \\ +0.025 \end{matrix}$
Over 30, up to and incl. 40	10 × 8	$d+3.5$	$10\begin{matrix} +0.061 \\ +0.025 \end{matrix}$
Over 40, up to and incl. 50	12 × 8	$d+3.5$	$12\begin{matrix} +0.035 \\ +0.032 \end{matrix}$
Over 50, up to and incl. 60	15 × 10	$d+5.0$	$15\begin{matrix} +0.075 \\ +0.032 \end{matrix}$
Over 60, up to and incl. 70	18 × 12	$d+6.0$	$18\begin{matrix} +0.075 \\ +0.032 \end{matrix}$
Over 70, up to and incl. 80	20 × 13	$d+6.0$	$20\begin{matrix} +0.092 \\ +0.040 \end{matrix}$
Over 80, up to and incl. 95	24 × 16	$d+8.0$	$24\begin{matrix} +0.092 \\ +0.040 \end{matrix}$

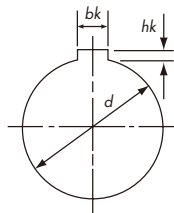

When you want us to make a keyway, please provided us with dimensions and tolerance. If no such information is given, the tolerances shown in the above tables are used.

### Machining of bores of standard stock pulleys

When machining a bore of a timing pulley, the best method is to chuck the outside diameter of the tooth part. However, the Tsubaki standard pulleys other than the AF type have their concentricity between the outside diameter of the tooth part and the outside diameter of the hub machined accurately. For this reason, when machining a bore, a recommended method is to chuck the outside diameter of the hub. When machining DF type pulleys, the flange rotates. To prevent it from rotating, insert a screw in the tapped hole.

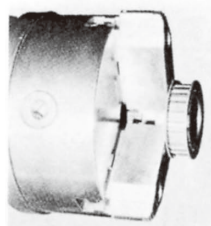

An example of chucking BF type

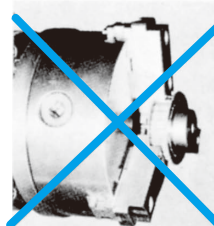

Never chuck flange part

### Other additional machining

#### ■ Tapping

When tapping the bottom, remove burrs completely as they will damage the belt. (For pulleys with hub, tap the hub.)

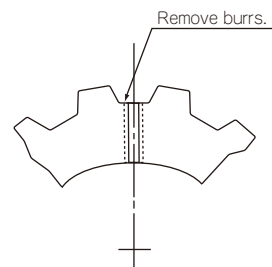



## DESIGN REFERENCE

### Other additional machining

#### Securing the flange

##### ● Clinching

Normally, pressed flanges and turned flanges are secured by clinching using a punch as shown below. The number of places to clinch is as follows:

Addendum Circle Diameter mm	Up to and incl. 30	Over 30, up to and incl. 50	Over 50, up to and incl. 120	Over 120, up to and incl. 250
Number of places to clinch	4	8	12	16

Precautions:

- Place a pulley on a flat table and clinch the flange using a punch.
- When clinching a place opposite the hub, inset the hub to a cylindrical fixture placed on the table to ensure it is stable.

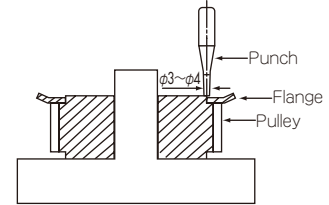

##### ● Securing with screws

Turned flanges for the large number of teeth of P8M, P14M may be secured to the pulley with countersunk head screws depending on applications. The number of screws shown in the following table is the minimum number.

Addendum Circle Diameter mm	Up to and incl. 120	Over 120, up to and incl. 250	Over 250, up to and incl. 450	Over 450, up to and incl. 650
Number of Screws	4	6	8	12

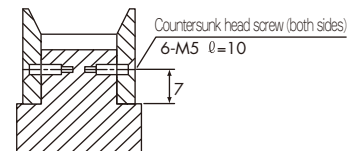

##### ● Securing by knurling

Another method often used for securing is knurling created with a lathe.

### Guide flange

#### General shape and standard dimensions

Type (Pitch)	Thickness <i>t</i>			OD <i>Df</i> Minimum	ID <i>df</i>
	Recommended		Normally used thickness		
	Press	Turning			
<b>P2M</b>	1.0	1.6	1.0~1.6	Do+ 4	Do-5
<b>P3M</b>				Do+ 4.5	
<b>P5M</b>		2.0		1.0~2.0	Do+ 6.3
<b>P8M</b>	1.6	2.5	1.6~2.5	Do+ 8	Do-10
<b>P14M</b>	—	4.0	4.0~5.0	Do+14	Do-20

Depending on standard flanges to use, the OD or ID may be different from those in the above table.

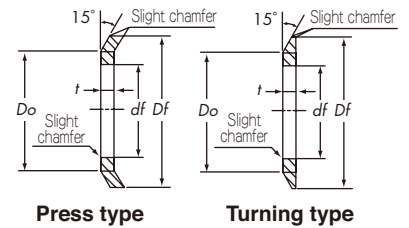



## DESIGN REFERENCE

### Guide flange

#### ■ Pulley dimensions when using a standard flange

● Dimensional tolerances of flange fitting part

Fitting Part Dimension $df$	Up to and incl. 25	Over 25, up to and incl. 50	Over 50 up to and incl. 100	Over 100 up to and incl. 180
Tolerance mm	-0.02 -0.05	-0.03 -0.07	-0.05 -0.10	-0.05 -0.15

● Stepped part length

Type (Pitch)	P3M	P5M	P8M	P14M
Stepped part length $L_f$ mm	2.0	2.2	2.6	5.0

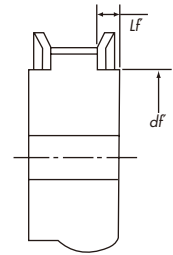

#### ■ Flange designation

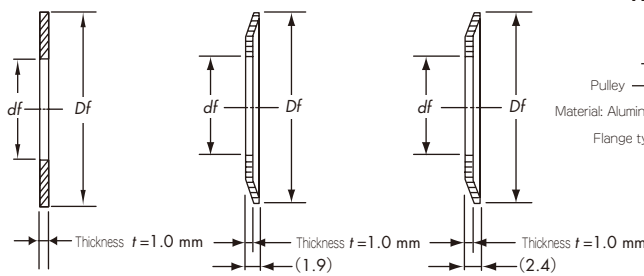

AS type··Material: Aluminum    AF type··Material: Aluminum    SF type··Material: SPCC

#### An example of designation

**PT A F 10 650 530**

Pulley  
Material: Aluminum  
Flange type  
Thickness  $t$ : 1.0 mm  
Inside diameter  $df$ : 53.0 mm  
Outside diameter  $D_f$ : 65.0 mm

### Unit mass of pulley materials

#### ■ Unit mass of pulley materials

Material	Unit Mass g/cm <sup>3</sup>
Carbon steel for machine structural use (S35C)	7.85
Aluminum (A2017-T4)	2.8
Stainless steel	7.8





## FLANGE DIMENSION

### ■ Flange Dimension(Aluminum)

● Thickness  $t=1.0\text{mm}$

type	Dimension mm		Number of teeth		
	Outside ( $D_f$ )	Inside ( $d_f$ )	P2M	P3M	P5M
PTAS1011040	11	4	12	—	—
PTAS1012055	12	5.5	14	10	—
PTAS1013070	13	7	15、16	11	—
PTAS1015080	15	8	17~19	12、13	—
PTAS10170100	17	10	20~24	14~16	—
PTAS10210133	21	13.3	25~27	17、18	—
PTAF10230120	23	12	—	—	—
PTAF10230130	23	13	—	—	12
PTAS10250150	25	15	28	—	—
PTAF10260150	26	15	29~31	19~21	13
PTAF10280160	28	16	32~34	22、23	14
PTAF10290180	29	18	35、36	24	15
PTAF10310190	31	19	37~39	25、26	16
PTAF10320212	32	21.2	40~42	27、28	17
PTAF10340230	34	23	43~45	29、30	—
PTAF10360224	36	22.4	46~48	31、32	18~20
PTAF10390265	39	26.5	49、50	33、34	21
PTAF10430300	43	30	—	35~38	22、23
PTAF10440310	44	31	—	39	24
PTAF10450335	45	33.5	60	40、41	25
PTAF10470355	47	35.5	—	42	26
PTAF10480375	48	37.5	64	43、44	27
PTAF10520375	52	37.5	—	45、46	28
PTAF10520400	52	40	—	47、48	29
PTAF10550425	55	42.5	72	49、50	30~32
PTAF10580450	58	45	—	—	33
PTAF10610490	61	49	80	56	34、35
PTAF10650530	65	53	90	60	37、38

### ■ Flange Dimension(SPCC)

● Thickness  $t=1.0\text{mm}$

type	Dimension mm		Number of teeth		
	Outside ( $D_f$ )	Inside ( $d_f$ )	P2M	P3M	P5M
PTSF10230120	23	12	—	—	—
PTSF10230130	23	13	—	—	12
PTSF10260150	26	15	29、30	—	13
PTSF10280160	28	16	31~34	22、23	14
PTSF10290180	29	18	35、36	24	15
PTSF10310190	31	19	37~39	25、26	16
PTSF10320212	32	21.2	40~42	27、28	17
PTSF10340230	34	23	43~45	29、30	—
PTSF10360224	36	22.4	48	31、32	18~20
PTSF10390265	39	26.5	49~51	33、34	21
PTSF10430300	43	30	52~57	35~38	22、23
PTSF10440310	44	31	58、59	39	24
PTSF10450335	45	33.5	60~62	40、41	25
PTSF10470355	47	35.5	63	42	26
PTSF10480375	48	37.5	64~66	43、44	27
PTSF10520375	52	37.5	67~69	45、46	28
PTSF10520400	52	40	70~72	47、48	29
PTSF10550425	55	42.5	73~77	49~52	30~32
PTSF10580450	58	45	78~82	53~55	33
PTSF10610490	61	49	83~87	56~58	34、35
PTSF10640500	64	50	88、89	59	36
PTSF10650530	65	53	90~92	60~62	37、38
PTSF10670560	67	56	93~98	63~67	39、40
PTSF10710600	71	60	99~103	68~70	41、42
PTSF10740630	74	63	104~107	71~74	43~45
PTSF10820670	82	67	110~120	75~81	46~48
PTSF10860710	86	71	121~126	82~86	49~52
PTSF101030850	103	85	—	93~103	57~62
PTSF1012001060	120	106	—	—	70~73



## FLANGE DIMENSION

### ■ Flange Dimension(Aluminum)

● Thickness  $t = 1.6\text{mm}$

type	Dimension mm		Number of teeth
	Outside ( $D_f$ )	Intside ( $d_f$ )	<b>P8M</b>
<b>PTSF16360224</b>	36	22.4	—
<b>PTSF16430300</b>	43	30	—
<b>PTSF16490335</b>	49	33.5	—
<b>PTSF16520375</b>	52	37.5	—
<b>PTSF16550425</b>	55	42.5	20
<b>PTSF16568420</b>	56.8	42	—
<b>PTSF16610450</b>	61	45	21
<b>PTSF16620450</b>	62	45	22
<b>PTSF16660500</b>	66	50	23、24
<b>PTSF16670530</b>	67	53	—
<b>PTSF16700560</b>	70	56	25
<b>PTSF16730560</b>	73	56	26
<b>PTSF16790630</b>	79	63	28
<b>PTSF16820670</b>	82	67	30
<b>PTSF16860710</b>	86	71	31、32、33
<b>PTSF16910770</b>	91	77	34
<b>PTSF16940770</b>	94	77	35
<b>PTSF16970800</b>	97	80	36
<b>PTSF161030850</b>	103	85	37、38
<b>PTSF161070900</b>	107	90	39、40
<b>PTSF161110950</b>	111	95	41、42
<b>PTSF1611501020</b>	115	102	43
<b>PTSF1611901020</b>	119	102	44、45
<b>PTSF1612701120</b>	127	112	46、47、48
<b>PTSF1613501150</b>	135	115	49
<b>PTSF1613501200</b>	135	120	50、51
<b>PTSF1613901250</b>	139	125	52、53
<b>PTSF1614301280</b>	143	128	54
<b>PTSF1615101370</b>	151	137	57
<b>PTSF1615801400</b>	158	140	58、59、60
<b>PTSF1616701520</b>	167	152	63、64
<b>PTSF1619001700</b>	190	170	72



## Precautions for handling timing belts

- The timing belts are flexible but stretch little and therefore cannot be set on a pulley by stretching it. If it is forced over the flange, a serious accident may result. Either shorten the center distance or keep the idler loose to set a timing belt.
- If the timing belt is to be used in a place where it is wetted by a large amount of water, protect the belt with a cover or other means.
- Use the timing belts in a clean environment in a temperature range of  $-15^{\circ}\text{C}$  to  $80^{\circ}\text{C}$ . If the belt is to be used in oily or dusty places, attach a cover to protect the belt.
- Do not use the timing belts in places where a large amount of oil or solution is used.

## Precautions for handling timing pulleys

- Do not damage the tooth face of timing pulleys. A force is transmitted by a pressure angle between a timing belt and a pulley with the timing belt wound around the addendum circle of the pulley. For this reason, unlike other gears, the addendum circle plays a very important role in power transmission.

## Storage of timing belts

- Do not curl timing belts at a small radius. The limit of curling is four times the pitch. If they are curled at a smaller radius, the core wires will be broken to result in a significant drop in the performance.

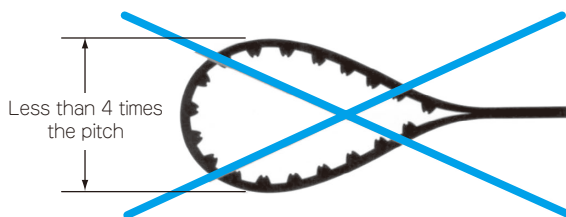

- A desirable place to store timing belts is a dry place at normal temperature. Do not store them in very hot, cold or humid places.

**For other handling precautions, see “For safe use of timing belts and pulleys” (page 3) also.**



## Troubleshooting

Problem	Cause	Corrective Action
1.Premature breakage of belt	Overload	Check the inertia of the driven object, motor, conditions of use, etc.
	Shock load	Increase the belt size or install a shock damping mechanism.
	Bent belt	Exercise caution during belt transportation, storage and installation.
	Too small pulley diameter	Increase the number of pulley teeth above the allowable minimum number of teeth.
2.Wear of belt teeth	Overload	Modify the design.
	Too high installation tension	Adjust the installation tension.
	Incorrect pulley tooth profile or incorrect dimensions of the tooth part	Use a pulley having the correct tooth profile and dimensions.
	Use in dusty atmosphere	Improve the atmosphere or install a cover.
3.Belt tooth jumping	Shock load	Increase the belt size.
	Insufficient belt installation tension	Apply an adequate installation tension.
	Insufficient number of meshed teeth	Either increase the number of pulley teeth or increase the number of meshed teeth by using an idler.
	Insufficient rigidity of frame on which belt is used	Use a frame having sufficient rigidity.
4.Shear breakage of belt teeth	Ultimate symptom of Problems 2 and 3	Same action as for Problems 2 and 3.
5.Tear and wear of belt side face	Poor parallelism between shafts	Make the shafts parallel.
	Poor pulley alignment	Align the pulleys accurately.
	Insufficient rigidity of frame on which belt is used	Use a frame having sufficient rigidity.
	Bent flange	Replace the bent flange with a good one or remedy the bent flange.
6.Longitudinal scratches on belt tooth surface	Belt running on edges of pulley	Align the pulleys and make the shafts parallel.
	Belt running on flange	Apply an adequate installation tension.
7.Partial cut of belt	Stuck foreign matter	Improve environment or install a cover.
	Belt running on flange	Apply an adequate belt installation tension and make the shafts parallel accurately.
8.Shrinkage of belt	Swelling due to oil	Either improve environment so that the belt is not wetted by oil or install a cover.
9.Apparent elongation of belt	Approaching shafts due to movement of shafts	Secure the bearing rigidly. If shock is strong, use a stopper to prevent the bearing from moving.
10.Sticky or softened rubber on back of belt	Slipping of back pushing idler	Apply an adequate installation tension. Reduce the inertia of the idler.
	Adhesion of oil	Either improve environment so that the belt is not wetted by oil or install a cover.
	Use in high temperature atmosphere	Lower the atmosphere temperature.
11.Wear of rubber on back of belt	Poor parallelism of back pushing idler shaft	Make the idler shaft parallel.
	Poor rotation of back pushing idler	Improve idler rotation.
12.Crack on rubber on back of belt	Too small pulley diameter	Increase the pulley diameter.
	Use in low temperature atmosphere	Optimize atmosphere temperature.
13.Wear of pulley teeth	Inadequate pulley material	Impart wear resistance to the pulley by using harder material, hardening the tooth surface or surface treatment.
	Use in dusty atmosphere	Improve the atmosphere or install a cover.
14.Noise	Too high installation tension	Apply an adequate installation tension.
	Overload	Increase the belt size.
	Poor shaft parallelism or poor pulley alignment	Make the shafts parallel and align the pulleys.

## PX PULLEY

mm

P2M						P3M						P5M					
No. of teeth	Pitch diameter	Outside diameter	No. of teeth	Pitch diameter	Outside diameter	No. of teeth	Pitch diameter	Outside diameter	No. of teeth	Pitch diameter	Outside diameter	No. of teeth	Pitch diameter	Outside diameter	No. of teeth	Pitch diameter	Outside diameter
14	8.91	8.40	81	51.57	51.06	10	9.55	8.79	81	77.35	76.59	14	22.28	21.14	81	128.92	127.77
15	9.55	9.04	82	52.20	51.69	11	10.50	9.74	82	78.30	77.54	15	23.87	22.73	82	130.51	129.37
16	10.19	9.68	83	52.84	52.33	12	11.46	10.70	83	79.26	78.50	16	25.46	24.32	83	132.10	130.96
17	10.82	10.31	84	53.48	52.97	13	12.41	11.65	84	80.21	79.45	17	27.06	25.91	84	133.69	132.55
18	11.46	10.95	85	54.11	53.60	14	13.37	12.61	85	81.17	80.41	18	28.65	27.51	85	135.28	134.14
19	12.10	11.59	86	54.75	54.24	15	14.32	13.56	86	82.12	81.36	19	30.24	29.10	86	136.87	135.73
20	12.73	12.22	87	55.39	54.88	16	15.28	14.52	87	83.08	82.32	20	31.83	30.69	87	138.46	137.32
21	13.37	12.86	88	56.02	55.51	17	16.23	15.47	88	84.03	83.27	21	33.42	32.28	88	140.06	138.91
22	14.01	13.50	89	56.66	56.15	18	17.19	16.43	89	84.99	84.23	22	35.01	33.87	89	141.65	140.51
23	14.64	14.13	90	57.30	56.79	19	18.14	17.38	90	85.94	85.18	23	36.61	35.46	90	143.24	142.10
24	15.28	14.77	91	57.93	57.42	20	19.10	18.34	91	86.90	86.14	24	38.20	37.06	91	144.83	143.69
25	15.92	15.41	92	58.57	58.06	21	20.05	19.29	92	87.85	87.09	25	39.79	38.65	92	146.42	145.28
26	16.55	16.04	93	59.21	58.70	22	21.01	20.25	93	88.81	88.05	26	41.38	40.24	93	148.01	146.87
27	17.19	16.68	94	59.84	59.33	23	21.96	21.20	94	89.76	89.00	27	42.97	41.83	94	149.61	148.46
28	17.83	17.32	95	60.48	59.97	24	22.92	22.16	95	90.72	89.96	28	44.56	43.42	95	151.20	150.06
29	18.46	17.95	96	61.12	60.61	25	23.87	23.11	96	91.67	90.91	29	46.15	45.01	96	152.79	151.65
30	19.10	18.59	97	61.75	61.24	26	24.83	24.07	97	92.63	91.87	30	47.75	46.60	97	154.38	153.24
31	19.74	19.23	98	62.39	61.88	27	25.78	25.02	98	93.58	92.82	31	49.34	48.20	98	155.97	154.83
32	20.37	19.86	99	63.03	62.52	28	26.74	25.98	99	94.54	93.78	32	50.93	49.79	99	157.56	156.42
33	21.01	20.50	100	63.66	63.15	29	27.69	26.93	100	95.49	94.73	33	52.52	51.38	100	159.15	158.01
34	21.65	21.14	101	64.30	63.79	30	28.65	27.89	101	96.45	95.69	34	54.11	52.97	101	160.75	159.60
35	22.28	21.77	102	64.94	64.43	31	29.60	28.84	102	97.40	96.64	35	55.70	54.56	102	162.34	161.20
36	22.92	22.41	103	65.57	65.06	32	30.56	29.80	103	98.36	97.60	36	57.29	56.15	103	163.93	162.79
37	23.55	23.05	104	66.21	65.70	33	31.51	30.75	104	99.31	98.55	37	58.89	57.75	104	165.52	164.38
38	24.19	23.68	105	66.85	66.34	34	32.47	31.71	105	100.27	99.51	38	60.48	59.34	105	167.11	165.97
39	24.83	24.32	106	67.48	66.97	35	33.42	32.66	106	101.22	100.46	39	62.07	60.93	106	168.70	167.56
40	25.46	24.96	107	68.12	67.61	36	34.38	33.62	107	102.18	101.42	40	63.66	62.52	107	170.30	169.15
41	26.10	25.59	108	68.75	68.25	37	35.33	34.57	108	103.13	102.37	41	65.25	64.11	108	171.89	170.75
42	26.74	26.23	109	69.39	68.88	38	36.29	35.53	109	104.09	103.33	42	66.85	65.70	109	173.48	172.34
43	27.37	26.87	110	70.03	69.52	39	37.24	36.48	110	105.04	104.28	43	68.44	67.29	110	175.07	173.93
44	28.01	27.50	111	70.66	70.16	40	38.20	37.44	111	106.00	105.24	44	70.03	68.89	111	176.66	175.52
45	28.65	28.14	112	71.30	70.79	41	39.15	38.39	112	106.95	106.19	45	71.62	70.48	112	178.25	177.11
46	29.28	28.78	113	71.94	71.43	42	40.11	39.35	113	107.91	107.15	46	73.21	72.07	113	179.85	178.70
47	29.92	29.41	114	72.57	72.07	43	41.06	40.30	114	108.86	108.10	47	74.80	73.66	114	181.44	180.29
48	30.56	30.05	115	73.21	72.70	44	42.02	41.25	115	109.82	109.05	48	76.39	75.25	115	183.03	181.89
49	31.19	30.69	116	73.85	73.34	45	42.97	42.21	116	110.77	110.01	49	77.99	76.84	116	184.62	183.48
50	31.83	31.32	117	74.48	73.98	46	43.93	43.16	117	111.73	110.96	50	79.58	78.44	117	186.21	185.07
51	32.47	31.96	118	75.12	74.61	47	44.88	44.12	118	112.68	111.92	51	81.17	80.03	118	187.80	186.66
52	33.10	32.60	119	75.76	75.25	48	45.84	45.07	119	113.64	112.87	52	82.76	81.62	119	189.39	188.25
53	33.74	33.23	120	76.39	75.89	49	46.79	46.03	120	114.59	113.83	53	84.35	83.21	120	190.99	189.84
54	34.38	33.87	121	77.03	76.52	50	47.75	46.98	121	115.55	114.78	54	85.94	84.80	121	192.58	191.44
55	35.01	34.51	122	77.67	77.16	51	48.70	47.94	122	116.50	115.74	55	87.54	86.39	122	194.17	193.03
56	35.65	35.14	123	78.30	77.80	52	49.66	48.89	123	117.46	116.69	56	89.13	87.98	123	195.76	194.62
57	36.29	35.78	124	78.94	78.43	53	50.61	49.85	124	118.41	117.65	57	90.72	89.57	124	197.35	196.21
58	36.92	36.42	125	79.58	79.07	54	51.57	50.80	125	119.37	118.60	58	92.31	91.17	125	198.94	197.80
59	37.56	37.05	126	80.21	79.71	55	52.52	51.76	126	120.32	119.56	59	93.90	92.76	126	200.53	199.39
60	38.20	37.69	127	80.85	80.34	56	53.48	52.71	127	121.28	120.51	60	95.49	94.35	127	202.13	200.98
61	38.83	38.33	128	81.49	80.98	57	54.43	53.67	128	122.23	121.47	61	97.08	95.94	128	203.72	202.58
62	39.47	38.96	129	82.12	81.62	58	55.39	54.62	129	123.19	122.42	62	98.67	97.53	129	205.31	204.17
63	40.11	39.60	130	82.76	82.25	59	56.34	55.58	130	124.14	123.38	63	100.27	99.13	130	206.90	205.76
64	40.74	40.24	131	83.40	82.89	60	57.30	56.53	131	125.10	124.33	64	101.86	100.72	131	208.49	207.35
65	41.38	40.87	132	84.03	83.53	61	58.25	57.49	132	126.05	125.29	65	103.45	102.31	132	210.08	208.94
66	42.02	41.51	133	84.67	84.16	62	59.21	58.44	133	127.01	126.24	66	105.04	103.90	133	211.68	210.53
67	42.65	42.15	134	85.31	84.80	63	60.16	59.40	134	127.96	127.20	67	106.63	105.49	134	213.27	212.13
68	43.29	42.78	135	85.94	85.44	64	61.12	60.35	135	128.92	128.15	68	108.23	107.08	135	214.86	213.72
69	43.93	43.42	136	86.58	86.07	65	62.07	61.31	136	129.87	129.11	69	109.82	108.67	136	216.45	215.31
70	44.56	44.06	137	87.22	86.71	66	63.03	62.26	137	130.83	130.06	70	111.41	110.27	137	218.04	216.90
71	45.20	44.69	138	87.85	87.35	67	63.98	63.22	138	131.78	131.02	71	113.00	111.86	138	219.63	218.49
72	45.84	45.33	139	88.49	87.98	68	64.94	64.17	139	132.74	131.97	72	114.59	113.45	139	221.22	220.08
73	46.47	45.97	140	89.13	88.62	69	65.89	65.13	140	133.69	132.93	73	116.18	115.04	140	222.81	221.67
74	47.11	46.60	141	89.76	89.26	70	66.85	66.08	141	134.65	133.88	74	117.77	116.63	141	224.41	223.27
75	47.75	47.24	142	90.40	89.89	71	67.80	67.04	142	135.60	134.84	75	119.36	118.22	142	226.00	224.86
76	48.38	47.88	143	91.04	90.53	72	68.75	67.99	143	136.55	135.79	76	120.95	119.81	143	227.59	226.45
77	49.02	48.51	144	91.67	91.17	73	69.71	68.95	144	137.51	136.75	77	122.54	121.41	144	229.18	228.04
78	49.66	49.15	145	92.31	91.80	74	70.66	69.90	145	138.46	137.70	78	124.13	123.00	145	230.77	229.63
79	50.29	49.78	146	92.95	92.44	75	71.62	70.86	146	139.42	138.66	79	125.72	124.59	146	232.36	231.22
80	50.93	50.42	147	93.58	93.08	76	72.57	71.81	147	140.37	139.61	80	127.31	126.18	147	233.95	232.81
			148	94.22	93.71	77	73.53	72.77	148	141.33	140.57				148	235.54	234.41
			149	94.86	94.35	78	74.48	73.72	149	142.28	141.52				149	237.13	236.00
			150	95.49	94.98	79	75.44	74.68	150	143.24	142.48				150	238.	

# Pitch and Outside Diameter



## PX PULLEY

mm

P8M						P14M					
No. of teeth	Pitch diameter	Outside diameter	No. of teeth	Pitch diameter	Outside diameter	No. of teeth	Pitch diameter	Outside diameter	No. of teeth	Pitch diameter	Outside diameter
			<b>81</b>	206.26	204.89				<b>81</b>	360.96	358.17
			<b>82</b>	208.81	207.44				<b>82</b>	365.42	362.63
			<b>83</b>	211.36	209.99				<b>83</b>	369.88	367.08
			<b>84</b>	213.90	212.53				<b>84</b>	374.33	371.54
			<b>85</b>	216.45	215.08				<b>85</b>	378.79	375.99
			<b>86</b>	219.00	217.63				<b>86</b>	383.25	380.45
			<b>87</b>	221.54	220.17				<b>87</b>	387.70	384.91
			<b>88</b>	224.09	222.72				<b>88</b>	392.16	389.36
			<b>89</b>	226.64	225.27				<b>89</b>	396.61	393.82
			<b>90</b>	229.18	227.81				<b>90</b>	401.07	398.28
<b>20</b>	50.93	49.56	<b>91</b>	231.73	230.36				<b>91</b>	405.53	402.73
<b>21</b>	53.48	52.10	<b>92</b>	234.28	232.90				<b>92</b>	409.98	407.19
<b>22</b>	56.02	54.65	<b>93</b>	236.82	235.45				<b>93</b>	414.44	411.65
<b>23</b>	58.57	57.20	<b>94</b>	239.37	238.00				<b>94</b>	418.90	416.10
<b>24</b>	61.12	59.75	<b>95</b>	241.92	240.54				<b>95</b>	423.35	420.56
<b>25</b>	63.66	62.29	<b>96</b>	244.46	243.09				<b>96</b>	427.81	425.01
<b>26</b>	66.21	64.84	<b>97</b>	247.01	245.64				<b>97</b>	432.26	429.47
<b>27</b>	68.75	67.38	<b>98</b>	249.55	248.18				<b>98</b>	436.72	433.93
<b>28</b>	71.30	69.93	<b>99</b>	252.10	240.73	<b>28</b>	124.78	121.98	<b>99</b>	441.18	438.38
<b>29</b>	73.85	72.48	<b>100</b>	254.65	253.28	<b>29</b>	129.23	126.44	<b>100</b>	445.63	442.84
<b>30</b>	76.39	75.02	<b>101</b>	257.19	255.82	<b>30</b>	133.69	130.90	<b>101</b>	450.09	447.30
<b>31</b>	78.94	77.57	<b>102</b>	259.74	258.37	<b>31</b>	138.15	135.35	<b>102</b>	454.55	451.75
<b>32</b>	81.49	80.12	<b>103</b>	262.29	260.92	<b>32</b>	142.60	139.81	<b>103</b>	459.00	456.21
<b>33</b>	84.03	82.66	<b>104</b>	264.83	263.46	<b>33</b>	147.06	144.27	<b>104</b>	463.46	460.67
<b>34</b>	86.58	85.21	<b>105</b>	267.38	266.01	<b>34</b>	151.52	148.72	<b>105</b>	467.92	465.12
<b>35</b>	89.13	87.75	<b>106</b>	269.93	268.55	<b>35</b>	155.97	153.18	<b>106</b>	472.37	469.58
<b>36</b>	91.67	90.30	<b>107</b>	272.47	271.10	<b>36</b>	160.43	157.63	<b>107</b>	476.83	474.03
<b>37</b>	94.22	92.85	<b>108</b>	275.02	273.65	<b>37</b>	164.88	162.09	<b>108</b>	481.28	478.49
<b>38</b>	96.77	95.39	<b>109</b>	277.57	276.19	<b>38</b>	169.34	166.55	<b>109</b>	485.74	482.95
<b>39</b>	99.31	97.94	<b>110</b>	280.11	278.74	<b>39</b>	173.80	171.00	<b>110</b>	490.20	487.40
<b>40</b>	101.86	100.49	<b>111</b>	282.66	281.29	<b>40</b>	178.25	175.46	<b>111</b>	494.65	491.86
<b>41</b>	104.41	103.03	<b>112</b>	285.21	283.83	<b>41</b>	182.71	179.92	<b>112</b>	499.11	496.32
<b>42</b>	106.95	105.58	<b>113</b>	287.75	286.38	<b>42</b>	187.17	184.37	<b>113</b>	503.57	500.77
<b>43</b>	109.50	108.13	<b>114</b>	290.30	288.93	<b>43</b>	191.62	188.83	<b>114</b>	508.02	505.23
<b>44</b>	112.05	110.67	<b>115</b>	292.85	291.47	<b>44</b>	196.08	193.28	<b>115</b>	512.48	509.68
<b>45</b>	114.59	113.22	<b>116</b>	295.39	294.02	<b>45</b>	200.54	197.74	<b>116</b>	516.94	514.14
<b>46</b>	117.14	115.77	<b>117</b>	297.94	296.57	<b>46</b>	204.99	202.20	<b>117</b>	521.39	518.60
<b>47</b>	119.68	118.31	<b>118</b>	300.48	299.11	<b>47</b>	209.45	206.65	<b>118</b>	525.85	523.05
<b>48</b>	122.23	120.86	<b>119</b>	303.03	301.66	<b>48</b>	213.90	211.11	<b>119</b>	530.30	527.51
<b>49</b>	124.78	123.41	<b>120</b>	305.58	304.21	<b>49</b>	218.36	215.57	<b>120</b>	534.76	531.97
<b>50</b>	127.32	125.95	<b>121</b>	308.12	306.75	<b>50</b>	222.82	220.02	<b>121</b>	539.22	536.42
<b>51</b>	129.87	128.50	<b>122</b>	310.67	309.30	<b>51</b>	227.27	224.48	<b>122</b>	543.67	540.88
<b>52</b>	132.42	131.04	<b>123</b>	313.22	311.84	<b>52</b>	231.73	228.94	<b>123</b>	548.13	545.34
<b>53</b>	134.96	133.59	<b>124</b>	315.76	314.39	<b>53</b>	236.19	233.39	<b>124</b>	552.59	549.79
<b>54</b>	137.51	136.14	<b>125</b>	318.31	316.94	<b>54</b>	240.64	237.85	<b>125</b>	557.04	554.25
<b>55</b>	140.06	138.68	<b>126</b>	320.86	319.48	<b>55</b>	245.10	242.30	<b>126</b>	561.50	558.70
<b>56</b>	142.60	141.23	<b>127</b>	323.40	322.03	<b>56</b>	249.55	246.76	<b>127</b>	565.95	563.16
<b>57</b>	145.15	143.78	<b>128</b>	325.95	324.58	<b>57</b>	254.01	251.22	<b>128</b>	570.41	567.62
<b>58</b>	147.70	146.32	<b>129</b>	328.50	327.12	<b>58</b>	258.47	255.67	<b>129</b>	574.87	572.07
<b>59</b>	150.24	148.87	<b>130</b>	331.04	329.67	<b>59</b>	262.92	260.13	<b>130</b>	579.32	576.53
<b>60</b>	152.79	151.42	<b>131</b>	333.59	332.22	<b>60</b>	296.38	264.59	<b>131</b>	583.78	580.99
<b>61</b>	155.34	153.96	<b>132</b>	336.14	334.76	<b>61</b>	271.84	269.04	<b>132</b>	588.24	585.44
<b>62</b>	157.88	156.51	<b>133</b>	338.68	337.31	<b>62</b>	276.29	273.50	<b>133</b>	592.69	589.90
<b>63</b>	160.43	159.06	<b>134</b>	341.23	339.86	<b>63</b>	280.75	277.96	<b>134</b>	597.15	594.36
<b>64</b>	162.97	161.60	<b>135</b>	343.77	342.40	<b>64</b>	285.21	282.41	<b>135</b>	601.61	598.81
<b>65</b>	165.52	164.15	<b>136</b>	346.32	344.95	<b>65</b>	289.66	286.87	<b>136</b>	606.06	603.27
<b>66</b>	168.07	166.70	<b>137</b>	348.87	347.50	<b>66</b>	294.12	291.32	<b>137</b>	610.52	607.72
<b>67</b>	170.61	169.24	<b>138</b>	351.41	350.04	<b>67</b>	298.57	295.78	<b>138</b>	614.97	612.18
<b>68</b>	173.16	171.79	<b>139</b>	353.96	352.59	<b>68</b>	303.03	300.24	<b>139</b>	619.43	616.64
<b>69</b>	175.71	174.34	<b>140</b>	356.51	355.14	<b>69</b>	307.49	304.69	<b>140</b>	623.89	621.09
<b>70</b>	178.25	176.88	<b>141</b>	359.05	357.68	<b>70</b>	311.94	309.15	<b>141</b>	628.34	625.55
<b>71</b>	180.80	179.43	<b>142</b>	361.60	360.23	<b>71</b>	316.40	313.61	<b>142</b>	632.80	630.01
<b>72</b>	183.35	181.97	<b>143</b>	364.15	362.77	<b>72</b>	320.86	318.06	<b>143</b>	637.26	634.46
<b>73</b>	185.89	184.52	<b>144</b>	366.69	365.32	<b>73</b>	325.31	322.52	<b>144</b>	641.71	638.92
<b>74</b>	188.44	187.07	<b>145</b>	369.24	367.87	<b>74</b>	329.77	326.98	<b>145</b>	646.17	643.38
<b>75</b>	190.99	189.61	<b>146</b>	371.79	370.41	<b>75</b>	334.23	331.43	<b>146</b>	650.63	647.83
<b>76</b>	193.53	192.16	<b>147</b>	374.33	372.96	<b>76</b>	338.68	335.89	<b>147</b>	655.08	652.29
<b>77</b>	196.08	194.71	<b>148</b>	376.88	375.51	<b>77</b>	343.14	340.34	<b>148</b>	659.54	656.74
<b>78</b>	198.63	197.25	<b>149</b>	379.43	378.05	<b>78</b>	347.59	344.80	<b>149</b>	663.99	661.20
<b>79</b>	201.17	199.80	<b>150</b>	381.97	380.60	<b>79</b>	352.05	349.26	<b>150</b>	668.45	665.66
<b>80</b>	203.72	202.35				<b>80</b>	356.51	353.71			



**DONGILGIUP**

(053-604-4841 )